

**be in motion be in motion**

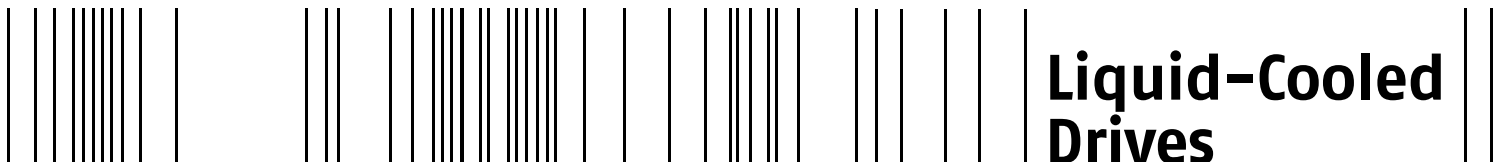

**Liquid-Cooled  
Drives**

DA...W..  
DS...W..



**Table of contents**

Liquid-cooled asynchronous and synchronous motors .....	2
General technical data .....	2
Winding isolation and temperature rise .....	3
Explanation of the motor data .....	3
Type key .....	4
Technical data asynchronous .....	6
Three-phase asynchronous DA 100..54 W.. (IP 54 water-cooled) .....	6
Dimension drawing DA 100 .....	7
Three-phase asynchronous DA 132..54 W.. (IP 54 water-cooled) .....	8
Dimension drawing DA 132 .....	9
Three-phase asynchronous DA 160..54 W.. (IP 54 water-cooled) .....	10
Dimension drawing DA 160 .....	11
Three-phase asynchronous DA 180..54 W.. (IP 54 water-cooled) .....	12
Dimension drawing DA 180 .....	13
Three-phase asynchronous DA 225..54 W.. (IP 54 water-cooled) .....	14
Dimension drawing DA 225 .....	15
Technical data synchronous .....	16
Three-phase synchronous DS 100..54 W.. (IP 54 water-cooled) .....	16
Dimension drawing DS 100 .....	17
Three-phase synchronous DS 132..54 W.. (IP 54 water-cooled) .....	18
Dimension drawing DS 132 .....	19
Three-phase synchronous DS 160..54 W.. (IP 54 water-cooled) .....	20
Dimension drawing DS 160 .....	21
Bearings and shaft load .....	22
Radial force diagrams .....	23
Main connection – Terminal marking .....	27
Thermal sensor .....	27
Noise intensity .....	28
Vibration severity .....	28
Requirements on the cooling circuit for liquid-cooled motors .....	28
Brake assignment .....	29
Encoder .....	30
Resolver .....	30
SINCOS SRS/SRM 50 (Stegmann) .....	31
ECN 1313 EQN 1325 (Heidenhain) .....	32
Dimension drawing of encoder boxes and connectors .....	33
Commissioning and maintenance instructions .....	33

## Liquid-cooled asynchronous and synchronous motors

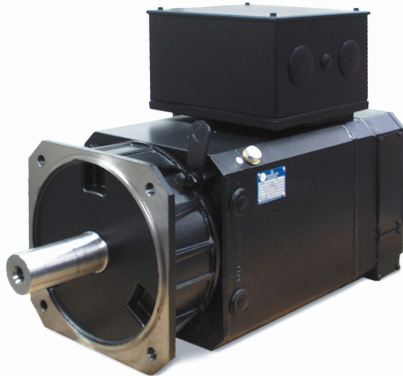

Compact machinery and systems call for professional energy management. The heat must be dissipated where it is generated.

Baumüller developed drives with liquid cooling especially for applications in energy-sensitive sectors such as the plastics or printing industry. These Baumüller drives cover the power range from 20 kW to 205 kW.

With liquid cooling the heat can be easily dissipated at source. That makes the new series of motors highly compact so it they have a higher level of power density than similarly designed air-cooled motors of protection type IP 54.

Due to the very high power density and high dynamic response the new series of motors is ideal for sophisticated applications in mechanical engineering. With liquid cooling there is no need for a fan unit so motor noise emission is reduced significantly.

The motors have large speed ranges. In addition, they feature roller bearings to cope with high lateral force loads. These durable, compact motors are also largely maintenance-free, which is an extra benefit to ensure efficient operation.

### General technical data

Version	IM B3, IM B5 IM B3, IM B35	Version 100 / 132 / 160 Frame size 180 / 225
Type of protection	IP54	liquid-cooled
Connection	Main connection Control connection Brake Thermal sensor	U V W Terminal box 12-pin connector Terminal box of brake in the main connection
Cooling method		IC 3W7 liquid-cooled
Thermal sensor		Linear thermal sensor for evaluation in the controller
Temperature rise		$\Delta\vartheta = 105K$ Insulation class F acc. to EN 60034-1
Temperature range		0...+ 40°C
Coolant input temperature		10°C to 35°C maximal 5 K lower than ambient temperature
Storage		-30°C...+85°C (for temperatures lower than 3 °C the cooling-water must be drained)
Paint	black matt	RAL 9005
Bearing		D-end: standard = ball bearing; option = roller bearing, locating bearing on the N-end
Terminal box		N-end; top
Water connection		D-end; lateral
Balance quality	N R, S	According to DIN ISO 2373 On request
Vibration-resistant up to	DA 100 - DA 225 DS 100 – DS 160	radial 3g / axial 1g, 10 Hz - 55 Hz acc. to EN 60068-2-6 radial 3g / axial 1g, 10 Hz - 55 Hz acc. to EN 60068-2-6 Higher vibration resistance on request
Flange		acc. to IEC standard
Shaft end	cylindrical	according to DIN 748 without key Centering with internal thread acc. to DIN 332 form D Also available with key DIN 6885 as an option
Brake		Disk brakes from Baumüller: N-end mounting as a module other brands on request

Actual speed encoder	2-pin resolver Option: Sincos Encoder Other encoders on request
UL design	Option in preparation

## Winding isolation and temperature rise

All machines of this series are designed in insulation class F according to EN 60034 for a permissible winding temperature of 105 K at a maximum permissible inlet temperature of 35 °C. The insulation is resistant against gases and vapours of combustible materials and it meets the requirements placed on a moisture-proof and tropical insulation.

A special insulation that can be obtained for an extra charge is necessary if concentrated acid vapours and metallic powders occur, with a permanent relative air humidity of more than 80% and as protection against termite and mould fungus attacks.

In the case of converters with a DC link voltage > 500 V, the cables between the converter and the motor must not be longer than 20 meters. For longer cables, additional measures (e.g. motor filters) must be provided. The maximum permissible terminal voltage is 1000 V.

## Explanation of the motor data

$P_N$	Nominal power ( kW ) with nominal speed $n_N$ in continuous operation (S1)
$M_N$	Nominal torque ( Nm ) with nominal speed $n_N$ in continuous operation (S1) Nominal speed ( $\text{min}^{-1}$ )
$n_1$	Limit speed for field weakening (constant power) ( $\text{min}^{-1}$ )
$n_{\text{max}}$	Mechanically permissible operating speed ( $\text{min}^{-1}$ )
$U_N$	Nominal voltage ( V )
$K_{E/COLD}$	Motor e.m.f. referred to 1000 $\text{min}^{-1}$ (voltage constant) ( V )
$I_N$	Nominal r.m.s. current ( A )
$I_{dN}$	Magnetizing current for field weakening ( A ), synchronous motor
$I_{\mu}$	Magnetizing current ( A ), asynchronous motor
$\cos \varphi$	Power factor
$\eta_N$	Efficiency
$f_N$	Nominal frequency ( Hz )
$J$	Rotor inertia incl. resolver without holding brake ( $\text{kg m}^2$ )
$m$	Weight ( kg )
$M_{0,\text{max}}$	Maximum standstill torque ( Nm )

## Ratings of asynchronous motors DA / synchronous motors DS

The specified ratings are achieved in inverter operation (field-oriented control) with a clock frequency of 4 kHz in the power stage. A chopping frequency of > 6 kHz is recommended.

## Overload capacity

According to technical data sheet

Type key

DA FF G 225 M 54 W 17 – 5 UL

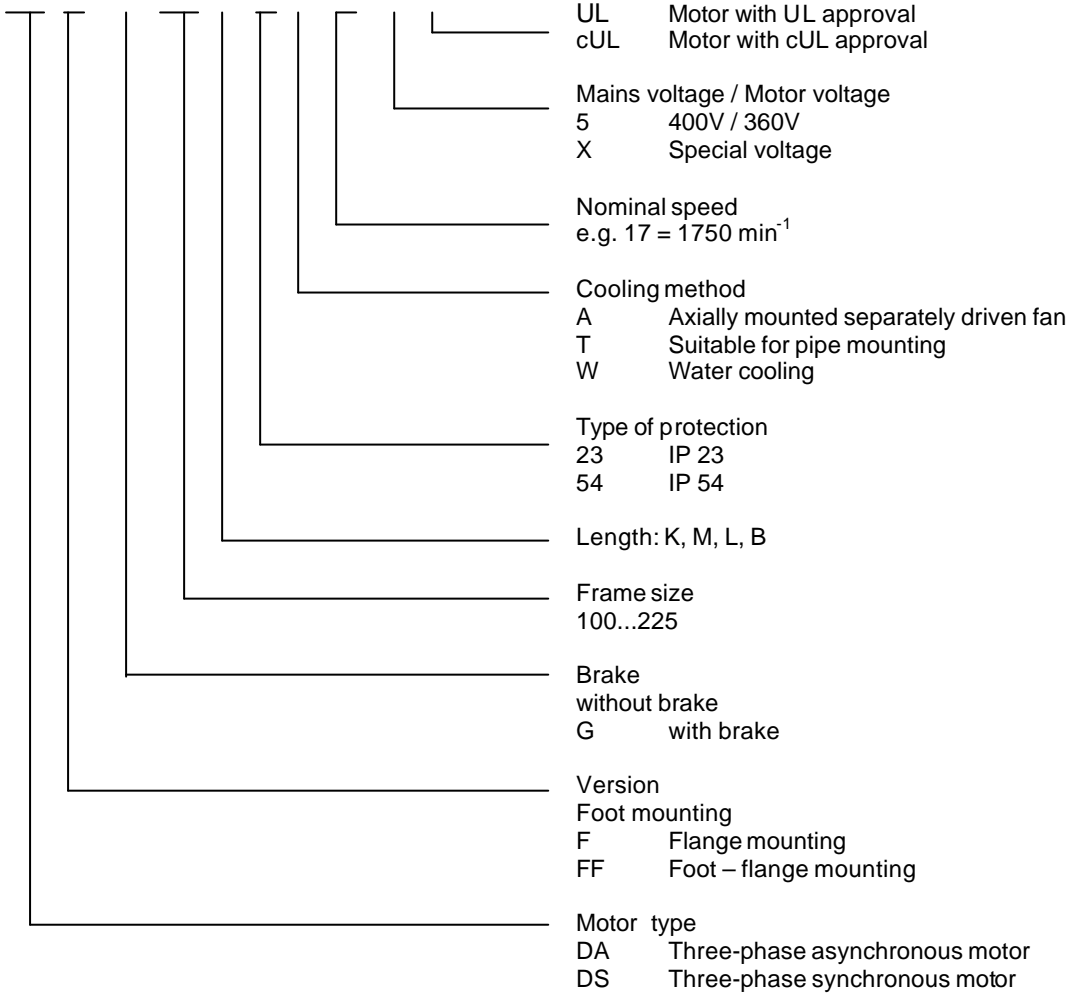



**Technical data asynchronous**
**Three-phase asynchronous DA 100..54 W.. (IP 54 water-cooled)**

Mains voltage 3 AC 400 V for converters with uncontrolled supply

Nom. speed	Motor type	Nom. power	Nom. torque	Nom. current	Nom. voltage	Limit speed with field weakening	Max. operating speed	Power factor	Magnetizing current	Efficiency	Nom. frequency	Inertia	Weight
$n_N$ min <sup>-1</sup>		$P_N$ kW	$M_N$ Nm	$I_N$ A	$U_N$ V	$n_1$ min <sup>-1</sup>	$n_{max}$ min <sup>-1</sup>	cos $\varphi$	$I_L$ A	$\eta_N$	$f_N$ Hz	J kgm <sup>2</sup>	m kg
1000	DA100K54W10-5	4.5	43	12.4	330	3000	8000	0.83	6.5	0.755	35.8	0.017	41
	DA100M54W10-5	6.5	62	17.2	335	3000	8000	0.84	8.9	0.776	35.8	0.023	51
	DA100L54W10-5	7.8	74	21.0	330	3000	8000	0.81	11.7	0.794	35.5	0.029	60
	DA100B54W10-5	9.0	86	23.5	340	2700	8000	0.80	13.5	0.805	35.4	0.034	68
1500	DA100K54W15-5	6.5	41	16.5	340	2800	8000	0.82	7.4	0.805	52.7	0.017	41
	DA100M54W15-5	9.0	57	23.5	335	3000	8000	0.79	11.9	0.826	52.4	0.023	51
	DA100L54W15-5	11.0	70	28.0	335	3000	8000	0.79	14.3	0.839	52.3	0.029	60
	DA100B54W15-5	13.0	83	32.5	345	2500	8000	0.79	16.8	0.847	52.3	0.034	68
2000	DA100K54W20-5	8.5	41	22.0	330	4000	8000	0.81	10.0	0.835	69.3	0.017	41
	DA100M54W20-5	12.0	57	30.0	330	4000	8000	0.81	13.4	0.853	69.2	0.023	51
	DA100L54W20-5	15.0	72	37.0	340	3800	8000	0.80	17.5	0.863	69.1	0.029	60
	DA100B54W20-5	17.5	84	41.0	350	3000	8000	0.81	18.5	0.870	69.1	0.034	68
2500	DA100K54W25-5	10.0	38	24.5	340	4700	8000	0.81	10.3	0.854	86.0	0.017	41
	DA100M54W25-5	15.0	57	37.0	335	5000	8000	0.80	16.7	0.867	85.9	0.023	51
	DA100L54W25-5	18.5	71	44.0	340	4700	8000	0.81	18.7	0.877	85.9	0.029	60
	DA100B54W25-5	22.0	84	55.0	330	5000	8000	0.80	25.5	0.883	85.7	0.034	68
3000	DA100K54W30-5	11.5	37	28.0	340	5700	8000	0.80	12.0	0.865	102.6	0.017	41
	DA100M54W30-5	17.0	54	40.0	340	5700	8000	0.81	16.2	0.879	102.6	0.023	51
	DA100L54W30-5	21.0	67	49.0	345	5100	8000	0.80	21.5	0.887	102.4	0.029	60
	DA100B54W30-5	25.0	80	57.0	350	4500	8000	0.80	25.5	0.893	102.3	0.034	68

**Maximum standstill torque**

Motor type	$M_{b\ max}$ [Nm]
DA100K54W	69
DA100M54W	99
DA100L54W	118
DA100B54W	138



**Dimension drawing DA 100**

Version IMB3 standard  
DA..100..54W..

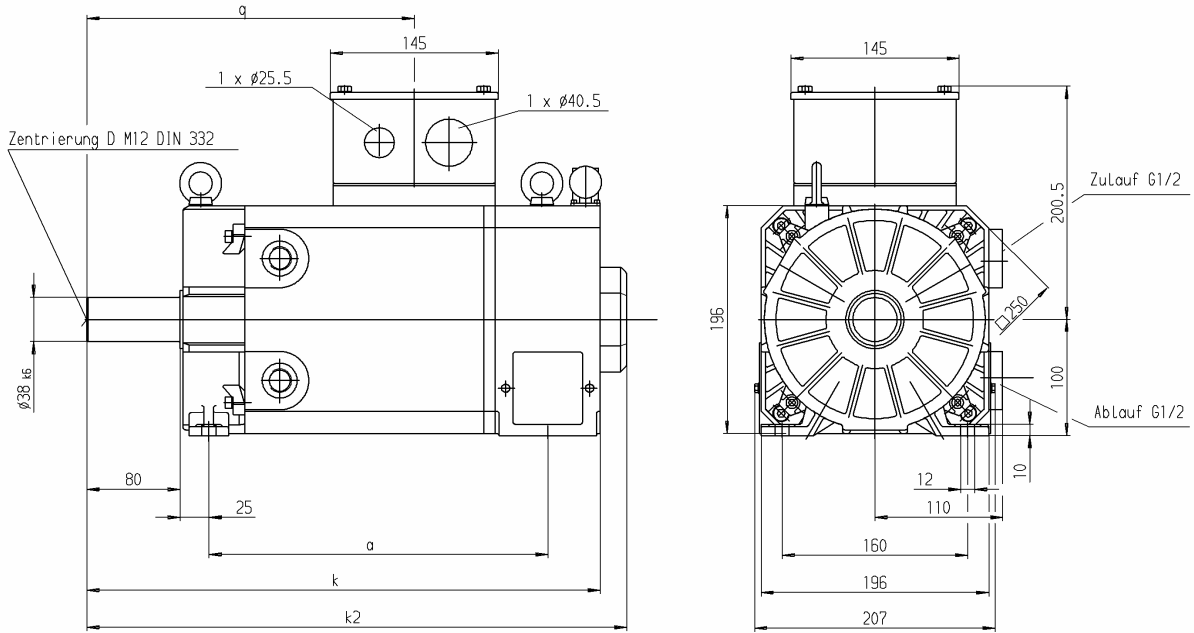

Version IMB5 standard  
DAF.100..54W..

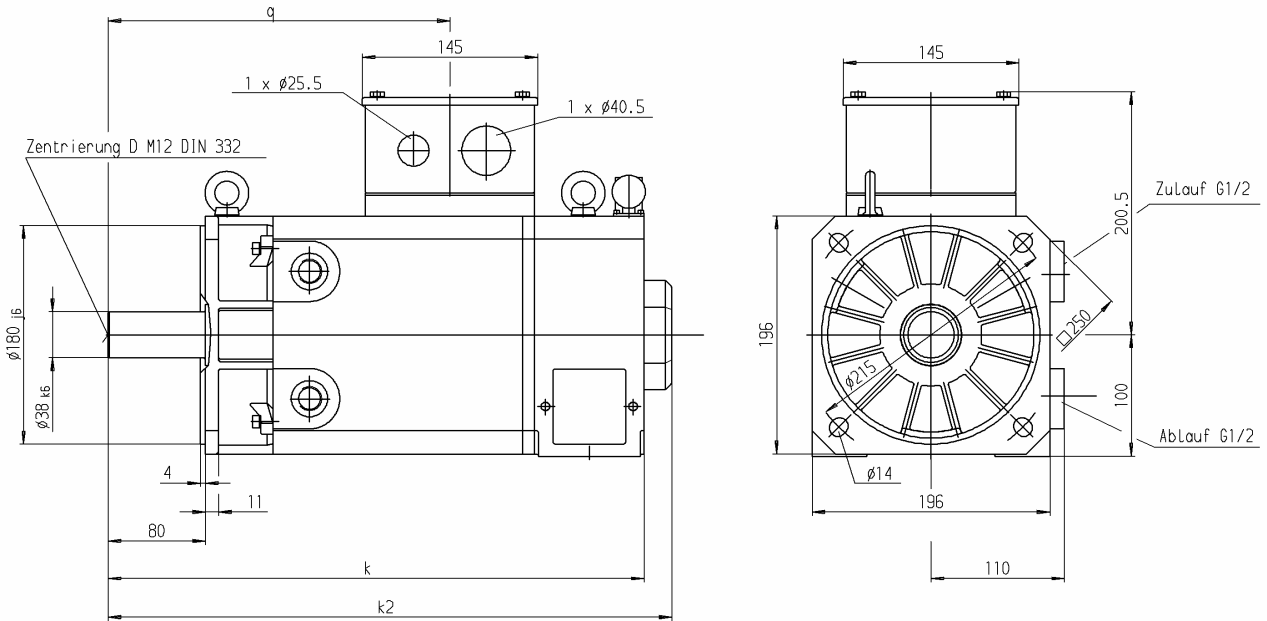

Type DA	a	k	k2	q
DA 100 K...W..	242	392	415	232
DA 100 M..W..	292	442	465	282
DA 100 L..W..	337	487	510	327
DA 100 B..W..	377	527	550	367

Brake k2 + 155 mm

**Three-phase asynchronous DA 132..54 W.. (IP 54 water-cooled)**

Mains voltage 3 AC 400 V for converters with uncontrolled supply

Nom. speed	Motor type	Nom. power	Nom. torque	Nom. current	Nom. voltage	Limit speed with field weakening	Max. operating speed	Power factor	Magnetizing current	Efficiency	Nom. frequency	Inertia	Weight
$n_N$ $\text{min}^{-1}$		$P_N$ kW	$M_N$ Nm	$I_N$ A	$U_N$ V	$n_1$ $\text{min}^{-1}$	$n_{\text{max}}$ $\text{min}^{-1}$	$\cos \varphi$	$I_L$ A	$\eta_N$	$f_N$ Hz	$J$ $\text{kgm}^2$	$m$ kg
1000	DA132K54W10-5	11.5	110	30.1	335	2600	5000	0.78	17.0	0.832	34.8	0.074	115
	DA132M54W10-5	13.7	131	36.0	330	3000	5000	0.78	20.7	0.846	34.7	0.090	130
	DA132L54W10-5	16.2	155	43.5	335	2600	5000	0.76	26.5	0.852	34.6	0.105	145
	DA132B54W10-5	18.3	175	45.5	340	2400	5000	0.79	25.5	0.864	34.6	0.120	160
1500	DA132K54W15-5	16.5	105	42.0	320	3000	5000	0.81	18.5	0.869	51.6	0.074	115
	DA132M54W15-5	20.0	127	48.5	340	2800	5000	0.79	22.5	0.879	51.5	0.090	130
	DA132L54W15-5	24.0	153	58.0	340	2800	5000	0.79	28.0	0.885	51.4	0.105	145
2000	DA132B54W15-5	27.5	175	66.0	345	2500	5000	0.78	33.0	0.890	51.4	0.120	160
	DA132K54W20-5	21.5	103	51.0	340	3800	5000	0.80	21.5	0.889	68.3	0.074	115
	DA132M54W20-5	26.5	127	66.0	335	4000	5000	0.77	32.5	0.894	68.1	0.090	130
2500	DA132L54W20-5	31.0	148	76.0	335	4000	5000	0.78	36.5	0.900	68.1	0.105	145
	DA132B54W20-5	36.0	172	83.0	345	3400	5000	0.80	36.5	0.904	68.1	0.120	160
	DA132K54W25-5	25.5	97	59.0	345	4200	5000	0.80	24.5	0.900	84.9	0.074	115
3000	DA132M54W25-5	31.0	118	73.0	335	5000	5000	0.80	31.5	0.905	84.8	0.090	130
	DA132L54W25-5	37.0	141	89.0	335	5000	5000	0.78	40.5	0.909	84.7	0.105	145
	DA132B54W25-5	43.0	164	99.0	345	4200	5000	0.79	44.0	0.913	84.7	0.120	160
	DA132K54W30-5	29.0	92	66.0	350	4500	5000	0.80	26.0	0.906	101.5	0.074	115
3000	DA132M54W30-5	36.0	115	86.0	335	5000	5000	0.79	36.0	0.911	101.4	0.090	130
	DA132L54W30-5	43.0	137	97.0	345	5000	5000	0.81	38.0	0.915	101.4	0.105	145
	DA132B54W30-5	50.0	159	109.0	355	4000	5000	0.81	44.0	0.919	101.4	0.120	160

**Maximum standstill torque**

Motor type	$M_{0 \text{ max}}$ [Nm]
DA132K54W	220
DA132M54W	262
DA132L54W	310
DA132B54W	350

**Dimension drawing DA 132**

Version IMB3 standard  
DA..132..54W..

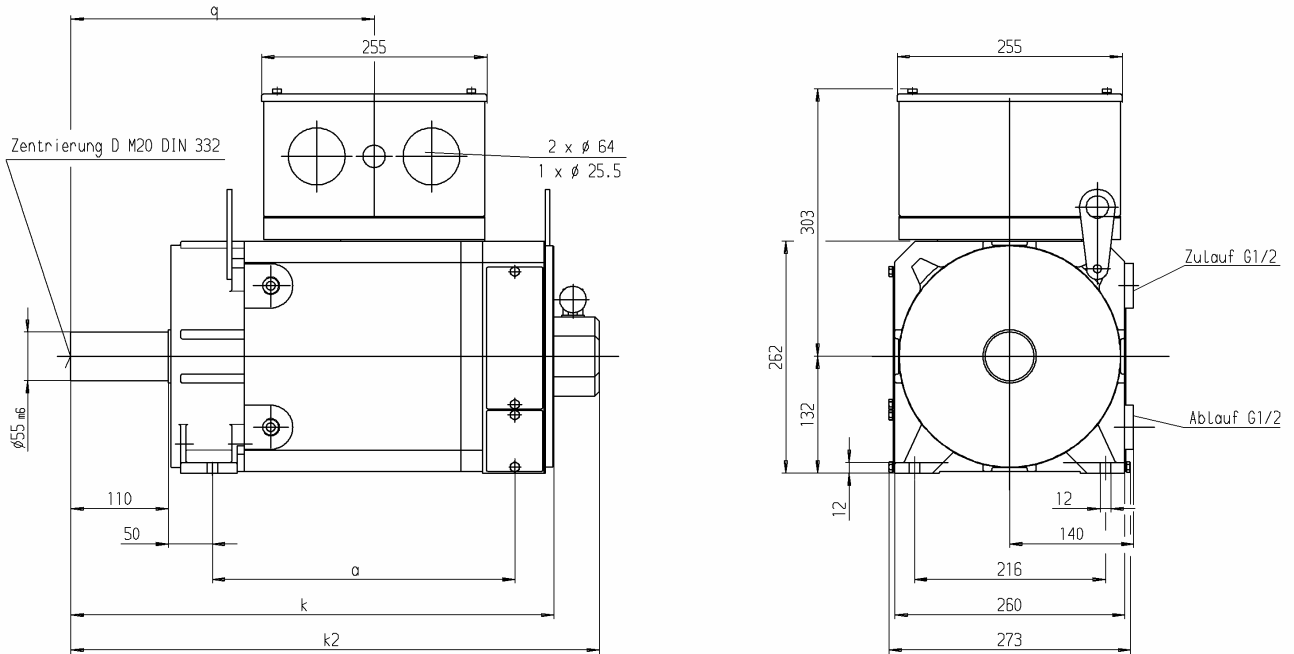

Version IMB5 standard  
DAF..132..54W..

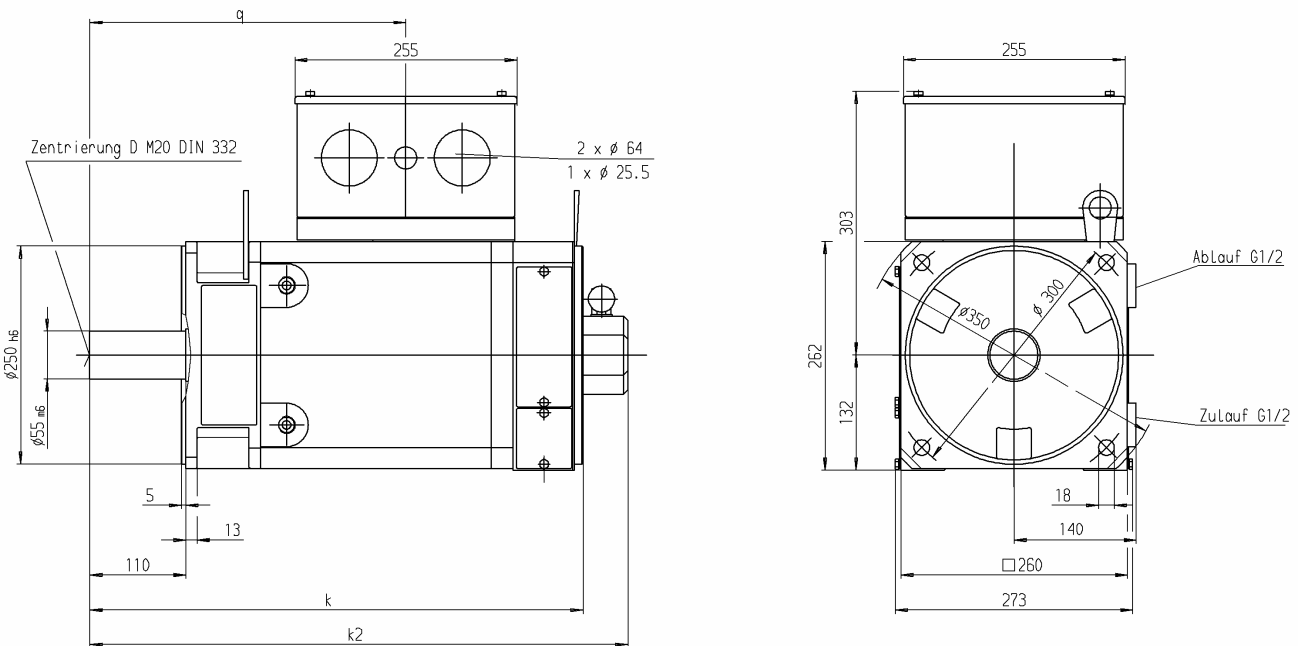

Type DA	a	k	k2	q
DA 132 K..W..	322	527	578	323
DA 132 M..W..	362	567	618	363
DA 132 L..W..	402	607	658	403
DA 132 B..W..	442	647	698	443

Brake k2 + 130 mm

**Three-phase asynchronous DA 160..54 W.. (IP 54 water-cooled)**

Mains voltage 3 AC 400 V for converters with uncontrolled supply

Nom. speed	Motor type	Nom. power	Nom. torque	Nom. current	Nom. voltage	Limit speed with field weakening	Max. operating speed	Power factor	Magnetizing current	Efficiency	Nom. frequency	Inertia	Weight
$n_N$ min <sup>-1</sup>		$P_N$ kW	$M_N$ Nm	$I_N$ A	$U_N$ V	$n_1$ min <sup>-1</sup>	$n_{max}$ min <sup>-1</sup>	cos $\varphi$	$I_L$ A	$\eta_N$	$f_N$ Hz	J kgm <sup>2</sup>	m kg
1000	DA160K54W10-5	26	248	59	345	2500	4500	0.82	28.5	0.882	34.5	0.245	235
	DA160M54W10-5	32	306	72	345	2500	4500	0.83	35.0	0.892	34.4	0.303	275
	DA160L54W10-5	37	353	85	340	3000	4500	0.83	42.0	0.896	34.4	0.346	310
1500	DA160K54W15-5	38	242	86	345	2400	4500	0.81	36.5	0.905	51.3	0.245	235
	DA160M54W15-5	47	299	105	345	2400	4500	0.83	43.5	0.912	51.2	0.303	275
	DA160L54W15-5	55	350	118	355	2200	4500	0.82	49.5	0.915	51.2	0.346	310
2000	DA160K54W20-5	48	229	100	350	3000	4500	0.85	36.0	0.920	68.0	0.245	235
	DA160M54W20-5	60	287	131	345	3500	4500	0.83	54.0	0.925	67.9	0.303	275
	DA160L54W20-5	70	334	153	350	3000	4500	0.82	66.0	0.928	67.8	0.346	310
2500	DA160K54W25-5	58	222	127	345	4500	4500	0.81	53.0	0.928	84.5	0.245	235
	DA160M54W25-5	72	275	149	355	3500	4500	0.84	56.0	0.932	84.5	0.303	275
	DA160L54W25-5	82	313	176	350	4000	4500	0.82	74.0	0.935	84.4	0.346	310
3000	DA160K54W30-5	65	207	141	345	4500	4500	0.82	58.0	0.933	101.2	0.245	235
	DA160M54W30-5	80	255	169	350	4500	4500	0.83	66.0	0.936	101.1	0.303	275
	DA160L54W30-5	92	293	210	325	4500	4500	0.83	85.0	0.938	101.1	0.346	310

**Maximum standstill torque**

Motor type	$M_{b\ max}$ [Nm]
DA160K54W	496
DA160M54W	612
DA160L54W	706

**Dimension drawing DA 160**

Version IMB3 standard  
DA..100..54W..

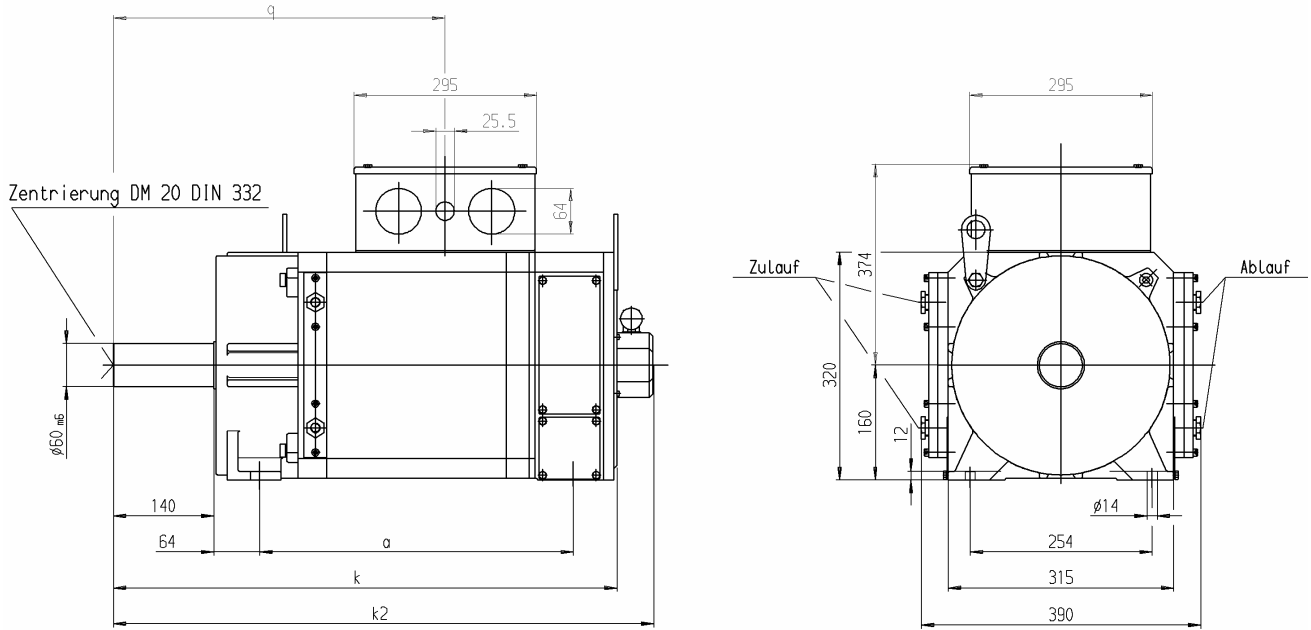

Version IMB5 standard  
DAF..160..54W..

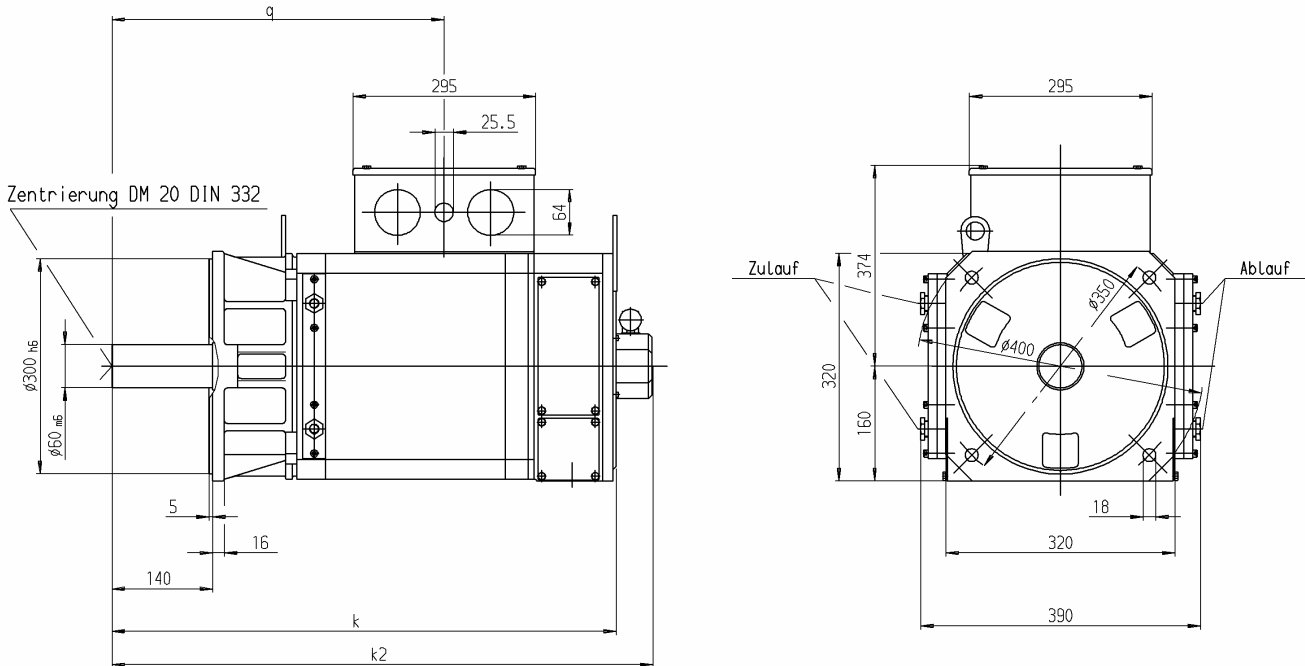

Type DA	a	k	k2	q
DA 160 K...W..	438	703	754	441
DA 160 M..W..	498	763	814	501
DA 160 L..W..	548	813	864	551

Brake k2 + 150 mm

**Three-phase asynchronous DA 180..54 W.. (IP 54 water-cooled)**

Mains voltage 3 AC 400 V for converters with uncontrolled supply

Nom. speed	Motor type	Nom. power	Nom. torque	Nom. current	Nom. voltage	Limit speed with field weakening	Max. operating speed	Power factor	Magnetizing current	Efficiency	Nom. frequency	Inertia	Weight
$n_N$ $\text{min}^{-1}$		$P_N$ kW	$M_N$ Nm	$I_N$ A	$U_N$ V	$n_1$ $\text{min}^{-1}$	$n_{\text{max}}$ $\text{min}^{-1}$	$\cos \varphi$	$I_L$ A	$\eta_N$	$f_N$ Hz	$J$ $\text{kgm}^2$	$m$ kg
1000	DA180M54W10-5	40	382	92	335	2000	4300	0.82	44	0.909	34.1	0.515	330
	DA180L54W10-5	57	544	132	335	2000	4300	0.82	66	0.913	34.1	0.676	435
1500	DA180M54W15-5	60	382	130	350	2300	4300	0.83	49	0.924	51.0	0.515	330
	DA180L54W15-5	84	535	180	350	2300	4300	0.84	66	0.928	50.9	0.676	435
2000	DA180M54W20-5	76	363	166	350	3000	4300	0.81	71	0.932	67.5	0.515	330
	DA180L54W20-5	105	501	255	315	4000	4300	0.80	113	0.935	67.5	0.676	435
2500	DA180M54W25-5	92	351	197	355	3500	4300	0.81	81	0.937	84.2	0.515	330
	DA180L54W25-5	122	466	248	360	3000	4300	0.83	89	0.940	84.2	0.676	435
3000	DA180MW30-5	102	325	235	340	4300	4300	0.79	103	0.937	100.8	0.515	330
	DA180L54W30-5	135	430	312	340	4300	4300	0.79	141	0.940	100.7	0.676	435

Maximum standstill torque

Motor type	$M_{b \text{ max}}$ [Nm]
DA180M54W	764
DA180L54W	1088

**Dimension drawing DA 180**

Version IMB3 standard  
DA..180..54W..

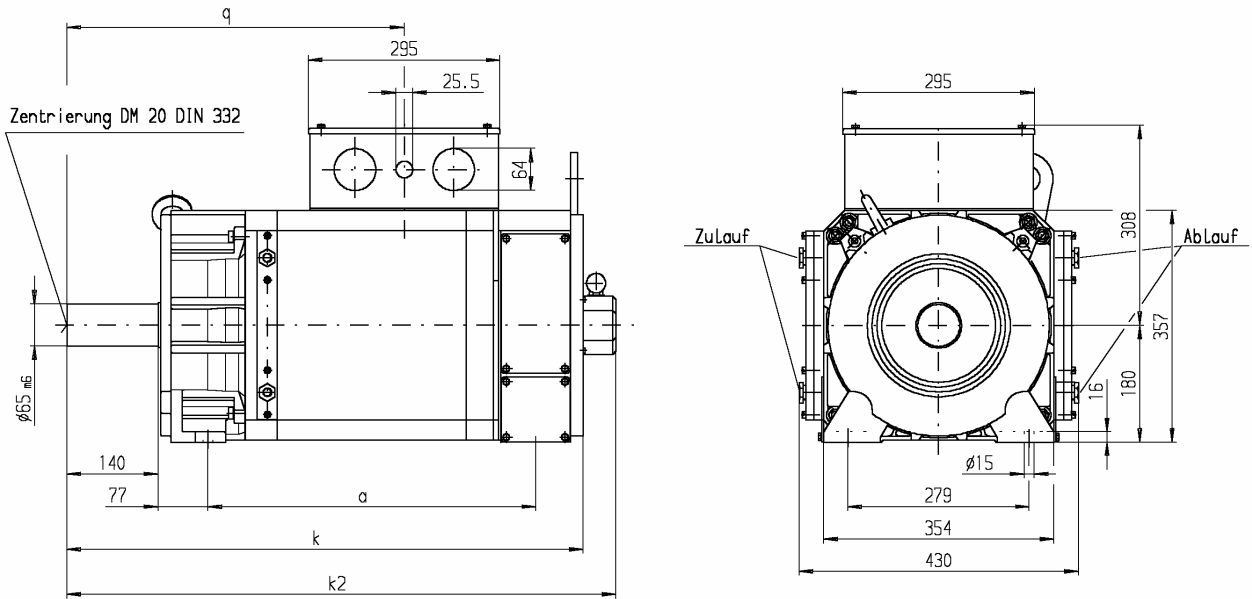

Version IMB35 standard  
DAFF..180..54W..

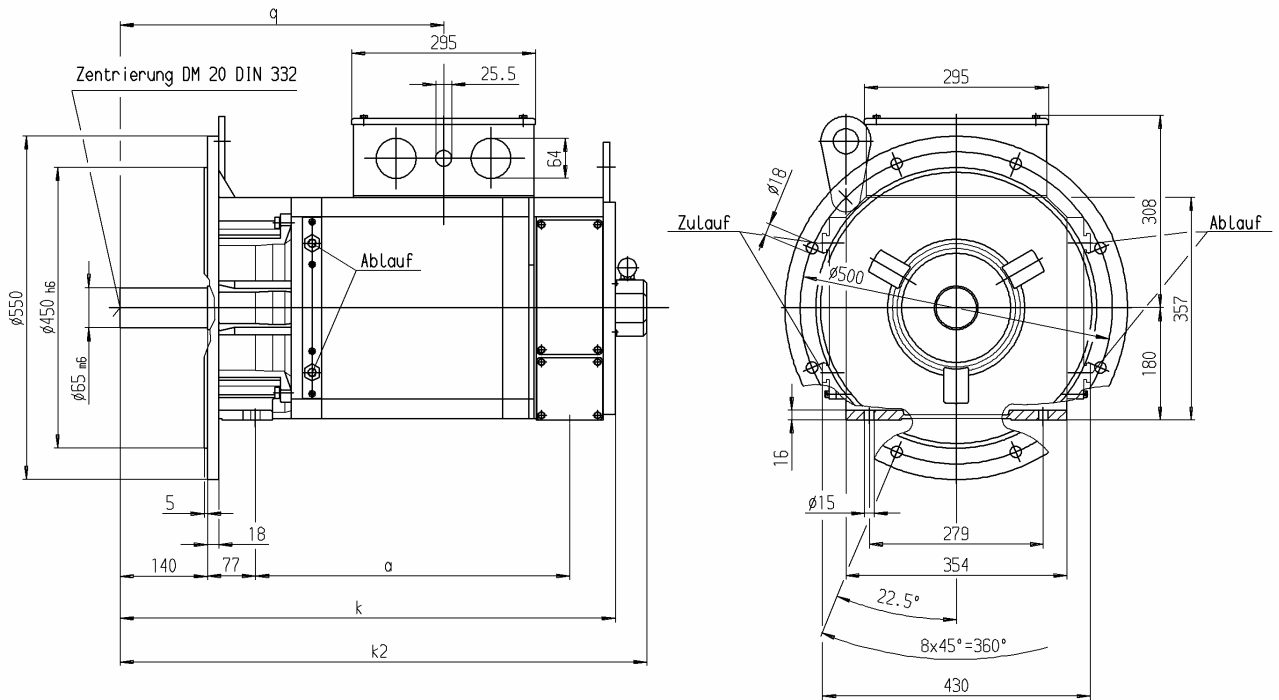

Type DA	a	k	k2	q
DA 180 M..W..	504	794	845	519
DA 180 L..W..	604	894	945	619

**Three-phase asynchronous DA 225..54 W.. (IP 54 water-cooled)**

Mains voltage 3 AC 400 V for converters with uncontrolled supply

Nom. speed	Motor type	Nom. power	Nom. torque	Nom. current	Nom. voltage	Limit speed with field weakening	Max. operating speed	Power factor	Magnetizing current	Efficiency	Nom. frequency	Inertia	Weight
$n_N$ $\text{min}^{-1}$		$P_N$ kW	$M_N$ Nm	$I_N$ A	$U_N$ V	$n_1$ $\text{min}^{-1}$	$n_{\text{max}}$ $\text{min}^{-1}$	$\cos \varphi$	$I_L$ A	$\eta_N$	$f_N$ Hz	$J$ $\text{kgm}^2$	$m$ kg
1000	DA225K54W10-5	68	649	161	325	2000	3800	0,81	71	0,926	33,9	1,313	600
	DA225M54W10-5	95	907	223	330	2000	3800	0,80	100	0,932	33,8	1,710	710
	DA225L54W10-5	120	1146	278	330	2000	3800	0,80	123	0,935	33,8	2,063	810
1500	DA225K54W15-5	97	618	208	350	2300	3800	0,81	85	0,940	50,6	1,313	600
	DA225M54W15-5	135	860	326	320	3000	3800	0,80	146	0,944	50,5	1,710	710
1750	DA225K54W17-5	108	589	244	340	3200	3800	0,80	107	0,943	58,9	1,313	600
	DA225M54W17-5	148	808	313	360	2300	3800	0,80	133	0,948	58,8	1,710	710
	DA225L54W17-5	185	1010	430	330	3500	3800	0,79	194	0,948	58,8	2,063	810
2000	DA225K54W20-5	120	573	300	310	3800	3800	0,79	137	0,943	67,2	1,313	600
	DA225M54W20-5	162	774	410	310	3800	3800	0,78	196	0,947	67,1	1,710	710
	DA225L54W20-5	205	979	423	355	3000	3800	0,82	162	0,952	67,2	2,063	810
250	DA225K54W25-5	135	516	280	360	3200	3800	0,82	108	0,948	83,8	1,313	600
	0												
3000	DA225M54W25-5	185	707	388	355	3500	3800	0,81	153	0,951	83,8	1,710	710
	DA225K54W30-5	150	478	360	330	3800	3800	0,78	164	0,946	100,4	1,313	600

## Maximum standstill torque

Motor type	$M_{0 \text{ max}}$ [Nm]
DA225K54W	1298
DA225M54W	1796
DA225L54W	2292



**Dimension drawing DA 225**

Version IMB3 standard  
DA..225..54W..

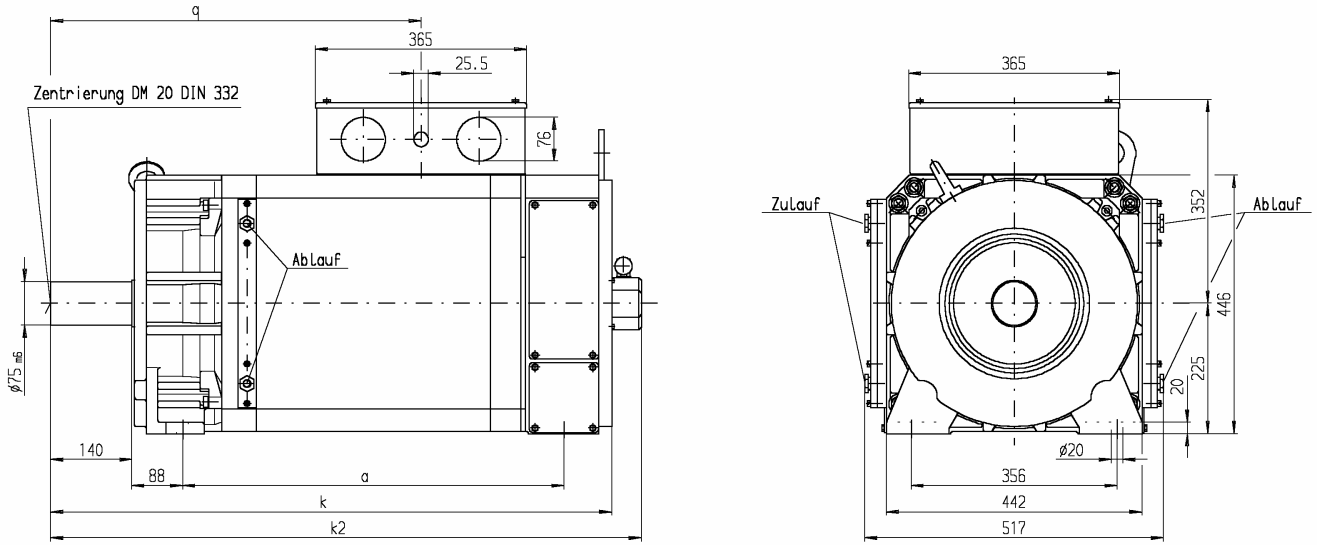

Version IMB35 standard  
DAFF..225..54W..

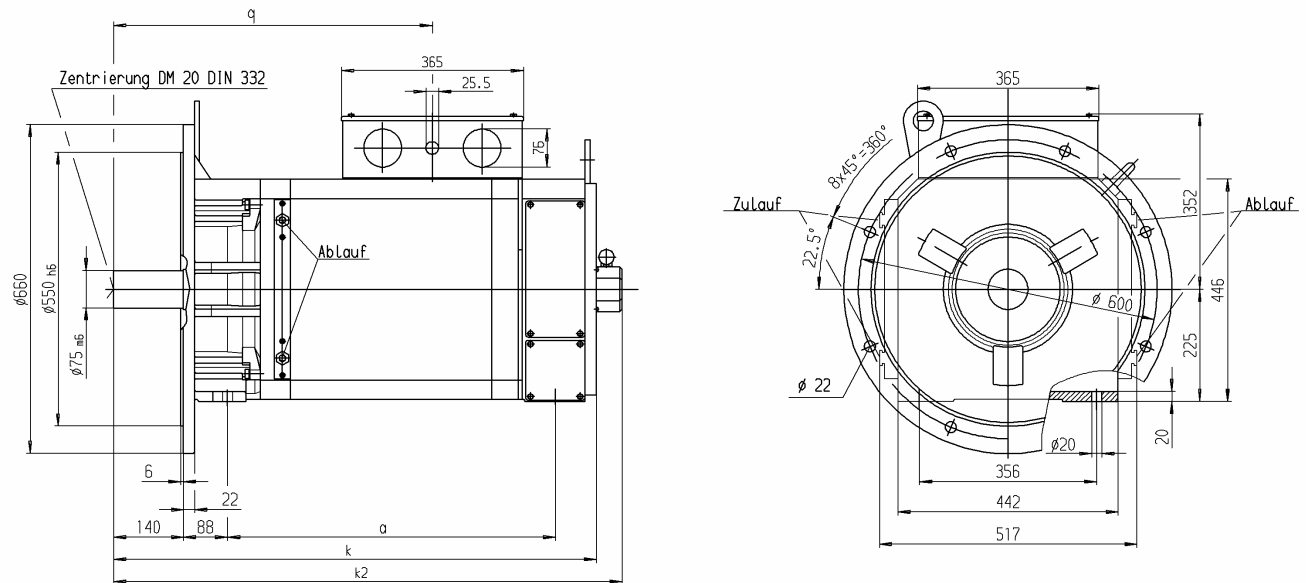

Type DA	a	k	k2	q
DA 225 K..W..	559	870	921	540
DA 225 M..W..	659	970	1021	640
DA 225 L..W..	749	1060	1111	730

**Technical data synchronous**
**Three-phase synchronous DS 100..54 W.. (IP 54 water-cooled)**

Mains voltage 3 AC 400 V for converters with uncontrolled supply

Nom. speed	Motor type	Nom. power	Nom. torque	Nom. current	Nom. voltage	Voltage constant	Power factor	Magnetizing current (field weakening)	Efficiency	Nom. frequency	Inertia	Weight
$n_N$ Min <sup>-1</sup>		$P_N$ kW	$M_N$ Nm	$I_N$ A	$U_N$ V	$K_{E./KALT}$ V/1000min <sup>-1</sup>	cos $\varphi$	$I_d$ A	$\eta_N$	$f_N$ Hz	J kgm <sup>2</sup>	M Kg
1000	DS100K54W10-5	5.9	56	13.0	345	276	0.90	0.0	0.843	50.0	0.010	38
	DS100M54W10-5	9.1	87	20.5	335	272	0.89	0.0	0.861	50.0	0.014	48
	DS100L54W10-5	12.3	118	27.5	340	277	0.88	0.0	0.871	50.0	0.018	58
	DS100B54W10-5	15.2	145	32.0	345	293	0.90	2.5	0.879	50.0	0.022	68
1500	DS100K54W15-5	8.7	55	18.0	340	198	0.92	2.0	0.884	75.0	0.010	38
	DS100M54W15-5	13.5	86	27.5	345	198	0.90	2.0	0.899	75.0	0.014	48
	DS100L54W15-5	18.2	116	36.0	350	208	0.91	4.5	0.906	75.0	0.018	58
	DS100B54W15-5	22.5	144	45.0	345	207	0.92	6.0	0.911	75.0	0.022	68
2000	DS100K54W20-5	11.4	54	22.0	350	162	0.94	4.5	0.905	100.0	0.010	38
	DS100M54W20-5	17.4	83	32.5	355	167	0.95	7.5	0.917	100.0	0.014	48
	DS100L54W20-5	23.5	112	45.0	345	166	0.95	11.0	0.923	100.0	0.018	58
	DS100B54W20-5	29.5	141	56.0	350	166	0.94	12.5	0.928	100.0	0.022	68
2500	DS100K54W25-5	13.7	52	26.0	345	134	0.96	7.5	0.917	125.0	0.010	38
	DS100M54W25-5	21.0	80	39.0	350	135	0.96	10.0	0.929	125.0	0.014	48
	DS100L54W25-5	28.5	109	53.0	345	138	0.96	16.0	0.933	125.0	0.018	58
	DS100B54W25-5	36.0	139	67.0	355	138	0.94	15.5	0.938	125.0	0.022	68
3000	DS100K54W30-5	16.2	52	30.5	345	113	0.96	8.0	0.927	150.0	0.010	38
	DS100M54W30-5	24.5	78	45.0	350	115	0.96	12.0	0.937	150.0	0.014	48
	DS100L54W30-5	34.0	108	63.0	350	115	0.95	17.0	0.941	150.0	0.018	58
	DS100B54W30-5	42.0	134	75.0	355	120	0.96	24.0	0.943	150.0	0.022	68

**Maximum standstill torque**

Motor type	$M_{0\ max}$ [Nm]
DS100K54W	128
DS100M54W	190
DS100L54W	250
DS100B54W	310

**Dimension drawing DS 100**

Version IMB3 standard  
DS. 100..54W..

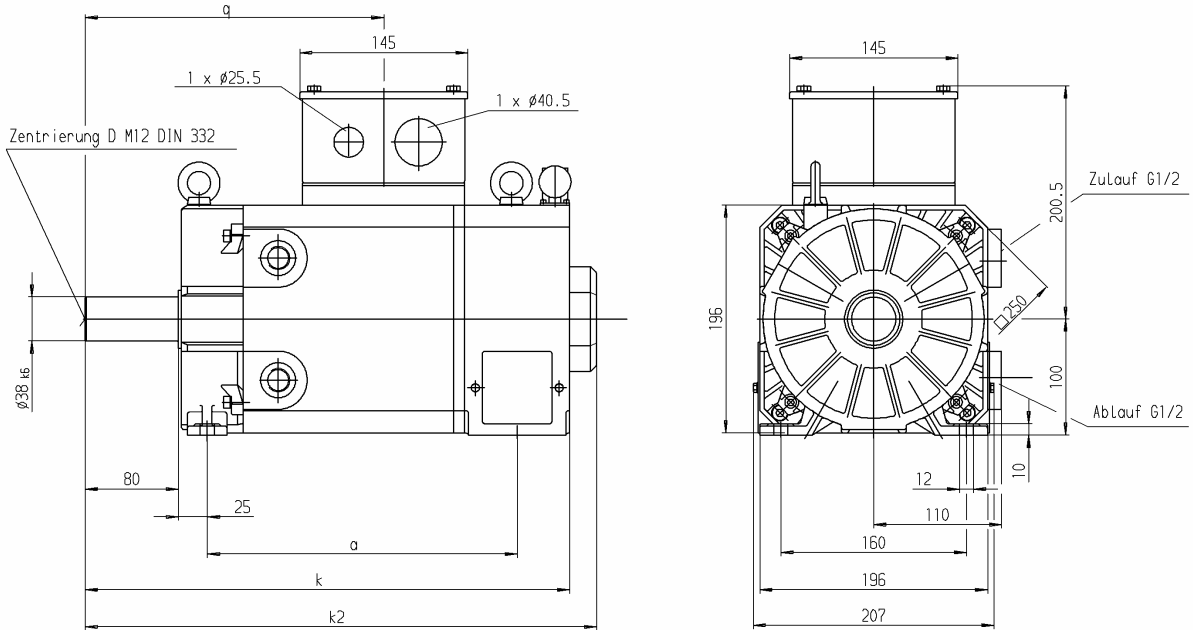

Version IMB5 standard  
DSF.100..54W..

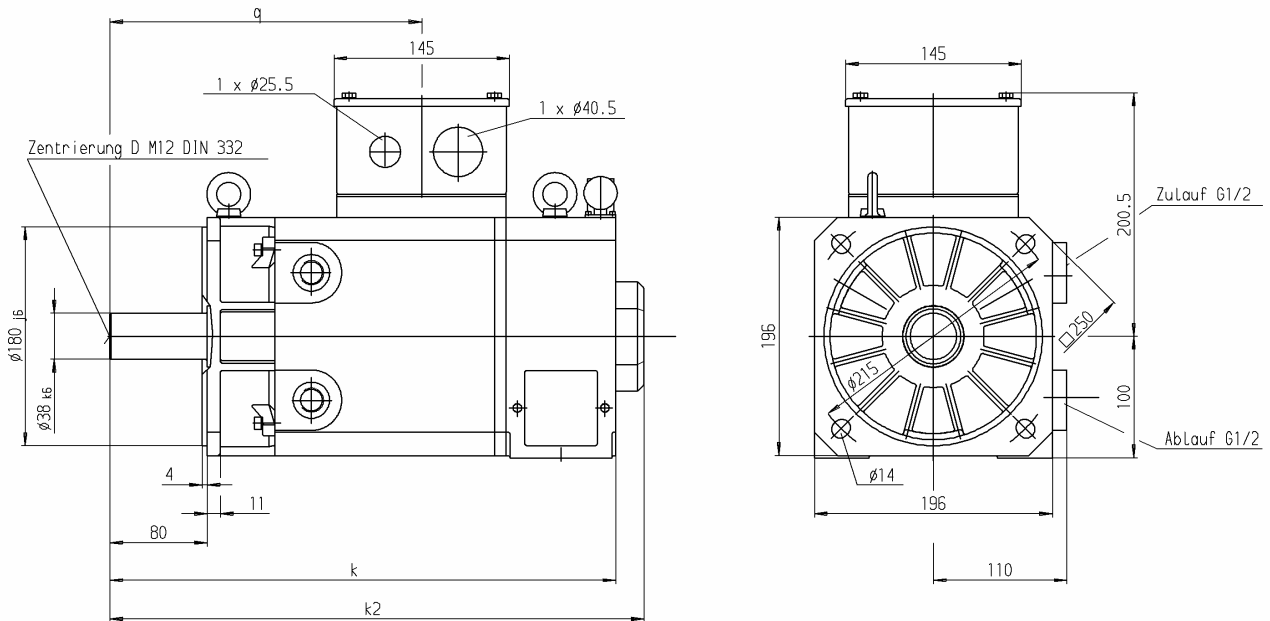

Type DS	a	k	k2	q
DS 100 K...W..	217	367	390	207
DS 100 M...W..	237	417	440	257
DS 100 L...W..	317	467	490	307
DS 100 B...W..	367	517	540	357

Brake k2 + 155 mm

**Three-phase synchronous DS 132..54 W.. (IP 54 water-cooled)**

Mains voltage 3 AC 400 V for converters with uncontrolled supply

Nom. speed	Motor type	Nom. power	Nom. torque	Nom. current	Nom. voltage	Voltage constant	Power factor	Magnetizing current (field weakening)	Efficiency	Nom. frequency	Inertia	Weight
$n_N$ Min <sup>-1</sup>		$P_N$ KW	$M_N$ Nm	$I_N$ A	$U_N$ V	$K_E/K_{ALT}$ V/1000min <sup>-1</sup>	cos $\varphi$	$I_d$ A	$\eta_N$	$f_N$ Hz	J kgm <sup>2</sup>	m kg
1000	DS132K54W10-5	15.3	146	31.5	350	297	0.89	0.0	0.909	50.0	0.045	100
	DS132M54W10-5	21.0	200	43.0	345	295	0.88	0.0	0.916	50.0	0.058	115
	DS132L54W10-5	26.0	249	51.0	345	319	0.93	8.5	0.920	50.0	0.071	130
	DS132B54W10-5	32.0	306	67.0	340	294	0.88	0.0	0.925	50.0	0.084	145
1500	DS132K54W15-5	22.5	143	43.5	350	208	0.91	3.0	0.933	75.0	0.045	100
	DS132M54W15-5	31.0	195	58.0	350	216	0.92	8.0	0.938	75.0	0.058	115
	DS132L54W15-5	39.0	247	73.0	350	221	0.93	12.5	0.941	75.0	0.071	130
	DS132B54W15-5	47.0	299	93.0	350	205	0.88	0.0	0.945	75.0	0.084	145
2000	DS132K54W20-5	29.0	138	54.0	350	162	0.93	7.5	0.945	100.0	0.045	100
	DS132M54W20-5	39.0	188	72.0	350	170	0.95	15.0	0.949	100.0	0.058	115
	DS132L54W20-5	50.0	239	92.0	350	172	0.94	20.5	0.951	100.0	0.071	130
	DS132B54W20-5	60.0	288	113.0	345	166	0.94	22.0	0.954	100.0	0.084	145
2500	DS132K54W25-5	35.0	134	64.0	350	133	0.94	10.5	0.951	125.0	0.045	100
	DS132M54W25-5	47.0	180	86.0	345	137	0.96	21.5	0.954	125.0	0.058	115
	DS132L54W25-5	61.0	233	113.0	345	139	0.96	29.5	0.956	125.0	0.071	130
	DS132B54W25-5	74.0	283	135.0	350	137	0.94	27.0	0.959	125.0	0.084	145
3000	DS132K54W30-5	40.0	127	71.0	350	119	0.97	20.5	0.954	150.0	0.045	100
	DS132M54W30-5	54.0	173	97.0	350	118	0.96	25.0	0.958	150.0	0.058	115
	DS132L54W30-5	72.0	229	132.0	350	115	0.95	28.0	0.960	150.0	0.071	130
	DS132B54W30-5	86.0	274	156.0	350	117	0.96	39.0	0.962	150.0	0.084	145

## Maximum standstill torque

Motor type	$M_0$ max [Nm]
DS132K54W	340
DS132M54W	450
DS132L54W	550
DS132B54W	660

**Dimension drawing DS 132**

Version IMB3 standard  
DS. 132..54W..

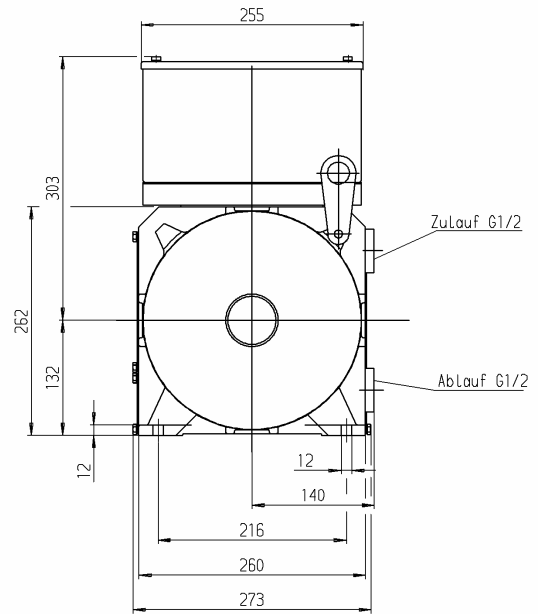
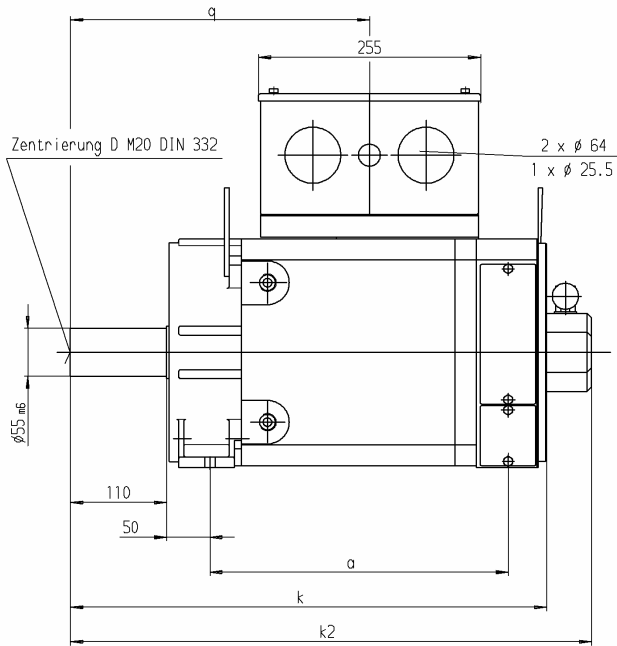

Version IMB5 standard  
DSF. 132..54W..

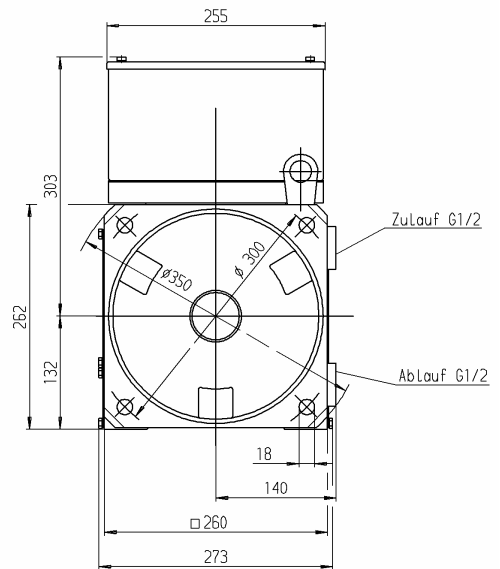
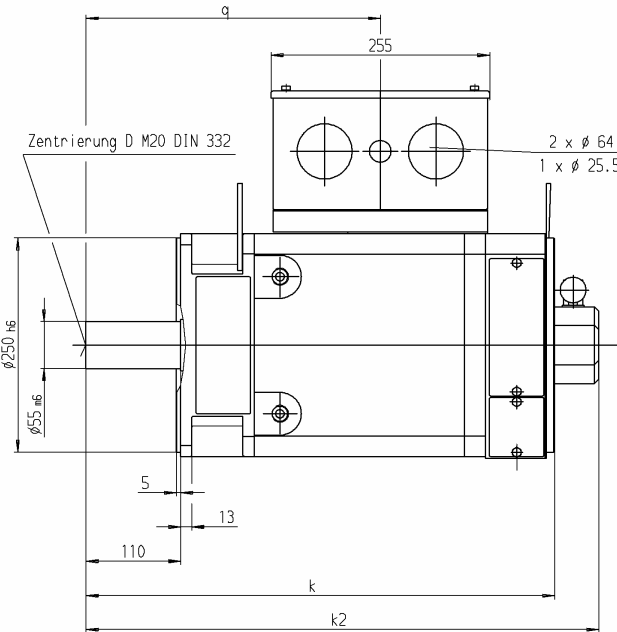

Type DS	a	k	k2	q
DS 132 K...W..	292	497	548	293
DS 132 M..W..	342	547	598	343
DS 132 L..W..	392	597	648	393
DS 132 B..W..	442	647	698	443

Brake k2 + 130 mm

**Three-phase synchronous DS 160..54 W.. (IP 54 water-cooled)**

Mains voltage 3 AC 400 V for converters with uncontrolled supply

Nom. speed	Motor type	Nom. power	Nom. torque	Nom. current	Nom. voltage	Voltage constant	Power factor	Magnetizing current (field weakening)	Efficiency	Nom. frequency	Inertia	Weight
$n_N$ Min <sup>-1</sup>		$P_N$ kW	$M_N$ Nm	$I_N$ A	$U_N$ V	$K_E/K_{ALT}$ V/1000min <sup>-1</sup>	cos $\varphi$	$I_d$ A	$\eta_N$	$f_N$ Hz	J kgm <sup>2</sup>	m kg
1000	DS160K54W10-5	30	287	56	345	334	0.96	9.5	0.937	50.0	0.150	175
	DS160M54W10-5	38	366	72	345	328	0.94	8.5	0.941	50.0	0.184	200
	DS160L54W10-5	46	441	87	345	330	0.94	9.0	0.944	50.0	0.217	225
	DS160B54W10-5	55	525	105	350	324	0.91	4.0	0.945	50.0	0.250	250
1500	DS160K54W15-5	44	280	81	345	221	0.95	10.0	0.952	75.0	0.150	175
	DS160M54W15-5	57	361	105	350	221	0.93	8.5	0.954	75.0	0.184	200
	DS160L54W15-5	68	435	131	345	214	0.91	0.0	0.957	75.0	0.217	225
	DS160B54W15-5	80	509	142	355	235	0.95	23.5	0.958	75.0	0.250	250
2000	DS160K54W20-5	56	269	102	345	170	0.96	15.0	0.958	100.0	0.150	175
	DS160M54W20-5	73	350	134	345	168	0.95	17.0	0.960	100.0	0.184	200
	DS160L54W20-5	87	415	155	350	176	0.96	28.0	0.962	100.0	0.217	225
	DS160B54W20-5	104	497	187	350	175	0.95	29.5	0.963	100.0	0.250	250
2500	DS160K54W25-5	68	260	124	345	135	0.95	13.5	0.961	125.0	0.150	175
	DS160M54W25-5	88	336	160	345	136	0.95	19.0	0.963	125.0	0.184	200
	DS160L54W25-5	107	409	195	345	137	0.95	28.5	0.964	125.0	0.217	225
	DS160B54W25-5	125	477	221	350	145	0.97	48.0	0.965	125.0	0.250	250
3000	DS160K54W30-5	78	248	137	350	118	0.97	22.5	0.962	150.0	0.150	175
	DS160M54W30-5	104	330	185	360	115	0.93	7.0	0.964	150.0	0.184	200
	DS160L54W30-5	122	390	213	350	125	0.98	63.0	0.965	150.0	0.217	225
	DS160B54W30-5	140	446	240	360	130	0.99	77.0	0.966	150.0	0.250	250

**Maximum standstill torque**

Motor type	$M_0 \text{ max}$ [Nm]
DS160K54W	685
DS160M54W	845
DS160L54W	1005
DS160B54W	1160

**Dimension drawing DS 160**

Version IMB3 standard  
DS. 160..54W..

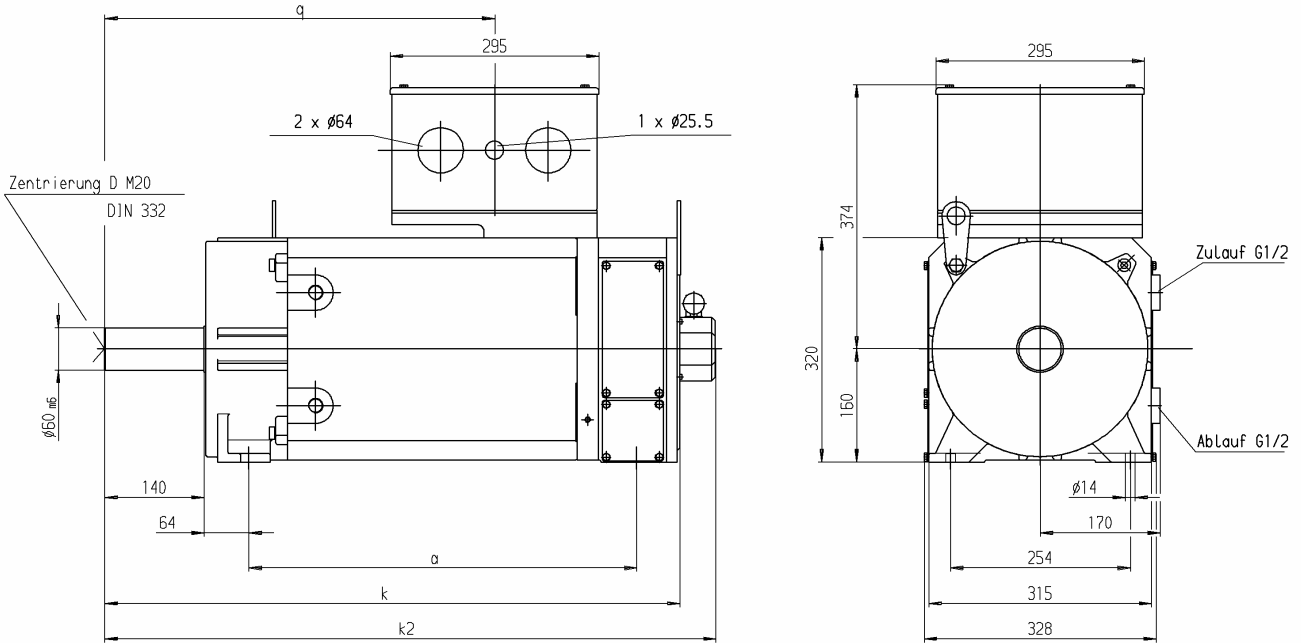

Version IMB5 standard  
DSF. 160..54W..

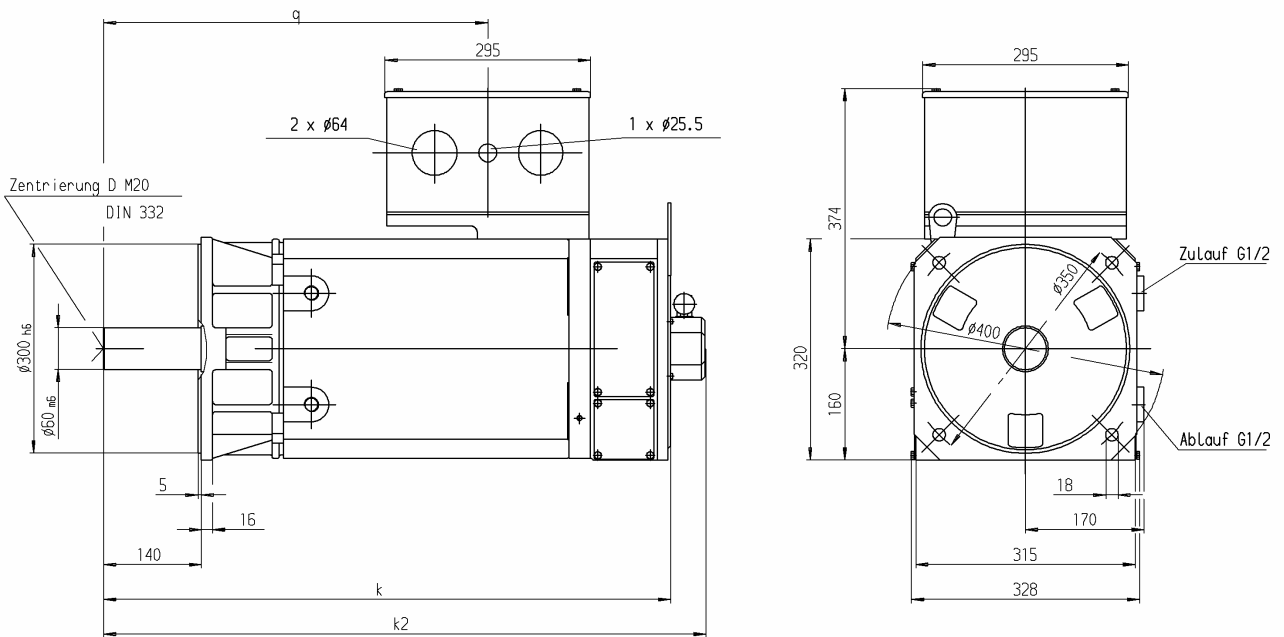

Type DS	a	k	k2	q
DS 160 K...W..	388	663	714	401
DS 160 M..W..	438	713	764	451
DS 160 L..W..	498	763	814	501
DS 160 B..W..	548	813	864	551

Brake k2 + 150 mm

## Bearings and shaft load

All machines are equipped with rolling-contact bearings. Normally, the non-locating bearing (ball bearing) is intended for the drive end and the locating bearing (ball bearing) for the non-drive end. Machines with roller bearings at the drive end are available for applications where increased radial forces can occur, for instance when using pulleys. Please specify radial forces in your order.

Ball bearing assignment for D-end

Ball bearing assignment for D-end

Frame size	D-end	N-end	Frame size	D-end	N-end
100	6209 2ZRC3	6306 2ZRC3	100	NU 209 E	6306 2ZRC3
132	6312 2ZRC3	6310 2ZRC3	132	NU 312 E	6310 2ZRC3
160	6313 2ZRC3	6311 2ZRC3	160	NU 313 E	6311 2ZRC3
180	6314 2ZRC3	6312 2ZRC3	180	NU 314 E	6312 2ZRC3
225	6316 2ZRC3	6314 2ZRC3	225	NU 316 E	6314 2ZRC3

### Determination of radial forces $F_R$

When using pulleys, the radial load is calculated according to the following formula:

$P$  = Nominal power in kW

$$F_R = k \frac{2 \cdot 10^7 \cdot P}{n \cdot D} \text{ [N]}$$

$n$  = Nominal speed in  $\text{min}^{-1}$

$D$  = Disk diameter in mm

The belt tightening factor  $k$  is approximately:

$k = 1.8 \dots 2.5$  for V-belt

$k = 2.2 \dots 3.5$  for flat belt

(Observe specifications of the belt manufacturer)

For a safe transmission of the torque it is necessary to utilise the entire bearing length of the key. Otherwise, an excessive compressive load per unit area may occur at the key which may result in a motor defect.

The pulley must be mounted up to the shaft shoulder and is tightened with the following tightening torques as a maximum.

Gland	M5	M6	M8	M10	M12	M16	M20
Tightening torque	2.2 Nm	4.0 Nm	10.0 Nm	19.0 Nm	33.0 Nm	80 Nm	160 Nm

### Permissible radial forces $F_R$ at the shaft end

The ball bearings are dimensioned for a calculated service life of approx. 20,000 operating hours <sup>1)</sup>. The load values specified in the following must not be exceeded. The specified permissible radial forces  $F_R$  are valid only for horizontal mounting of the motor without additional axial forces. If additional forces occur, please consult the manufacturer.

### Axial load of the motor shaft

When mounting clutches, pulleys, etc. onto the motor shaft, axial forces must not occur! Therefore use the internal thread of the shaft end as assembly aid.

1) medium operating temperature < 90 °C

medium operating speed < 2000 U/min (DA 100 – DA 160), medium operating speed < 1500 U/min (DA 180 – DA 225)

medium operating speed < 2000 U/min (DS 100 – DS 160)



## Radial force diagrams

### Example

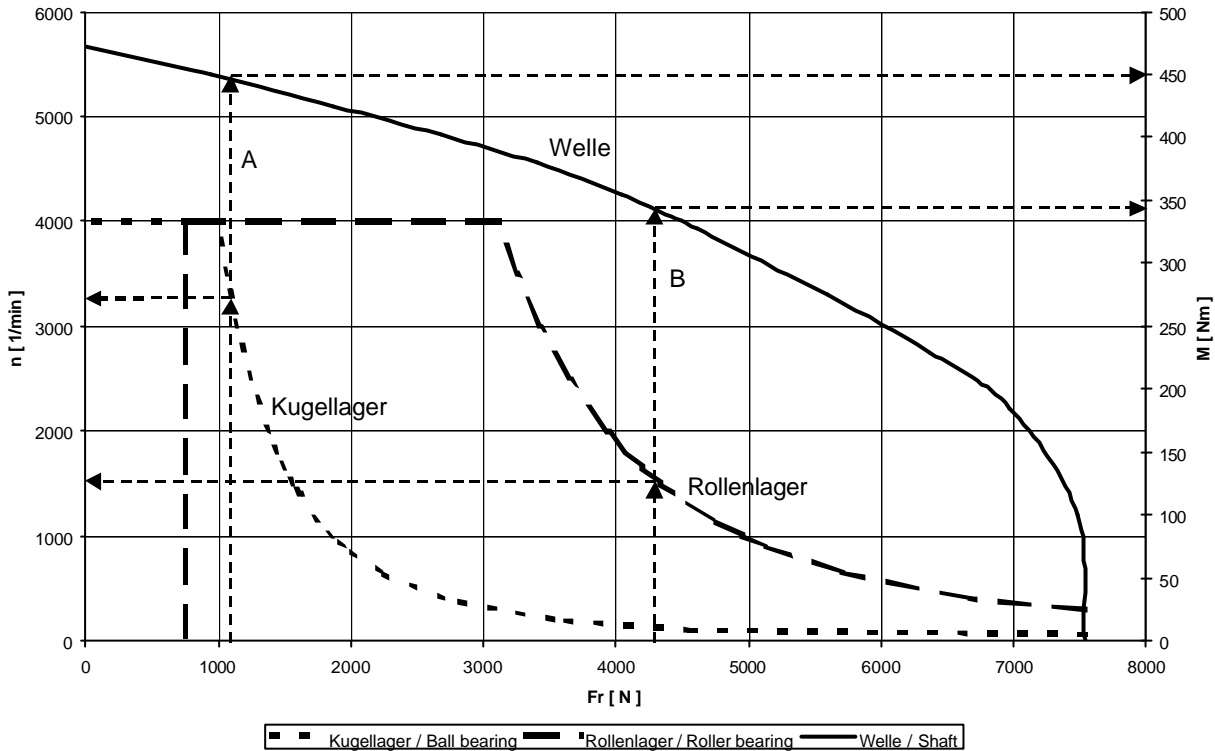

### Explanation of the example

Force acting on the end of the shaft end (for force acting on the middle of the shaft end  $Fr \times 1.1$ )  
 Shaft end with keyway

#### Case A – Ball bearing:

The radial force  $Fr$  of the application is used to determine the possible maximum speed of the bearing in the “Ball bearing” characteristic.

Radial force 1100 N  $\Rightarrow$  maximum speed 3250  $\text{min}^{-1}$

The maximum transmittable torque results from the “Shaft” characteristic.

Radial force 1100 N  $\Rightarrow$  maximum transmittable torque 450 Nm

#### Case B – Roller bearing:

The radial force  $Fr$  of the application is used to determine the possible maximum speed of the bearing in the “Roller bearing” characteristic.

Radial force 4,300 N  $\Rightarrow$  maximum speed 1,500  $\text{min}^{-1}$

The maximum transmittable torque results from the “Shaft” characteristic.

Radial force 4,300 N  $\Rightarrow$  maximum transmittable torque 345 Nm

The roller bearing requires a minimum radial force of 800 N to avoid bearing damage.

DA 100 / DS 100

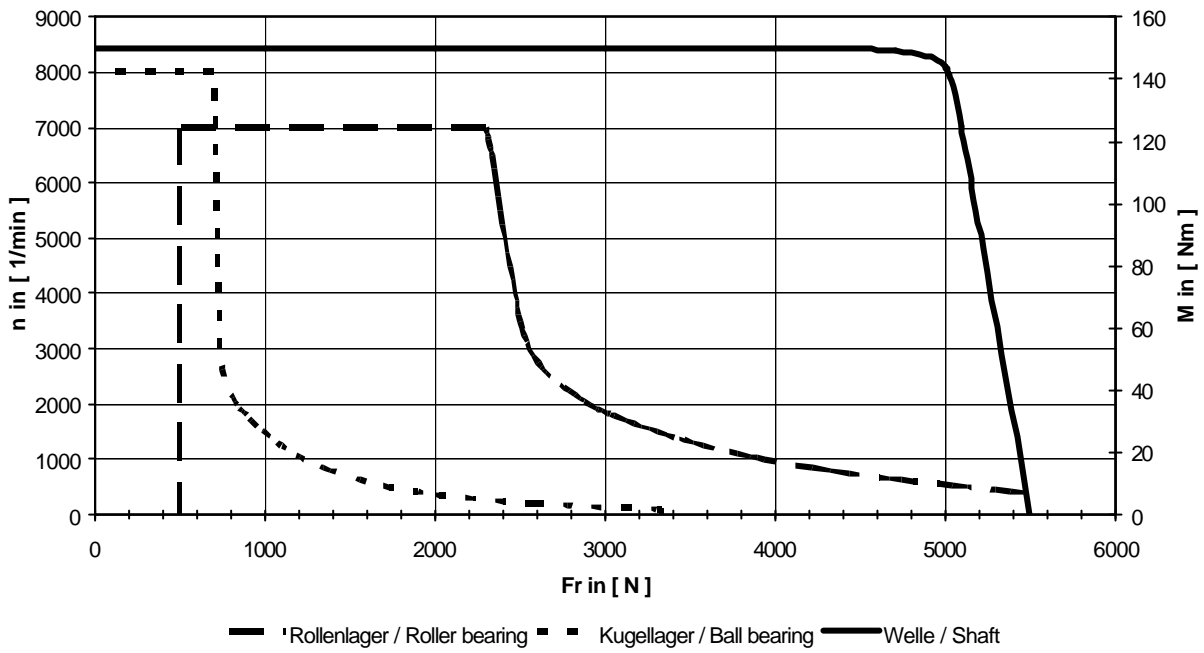

DA 132 / DS 132

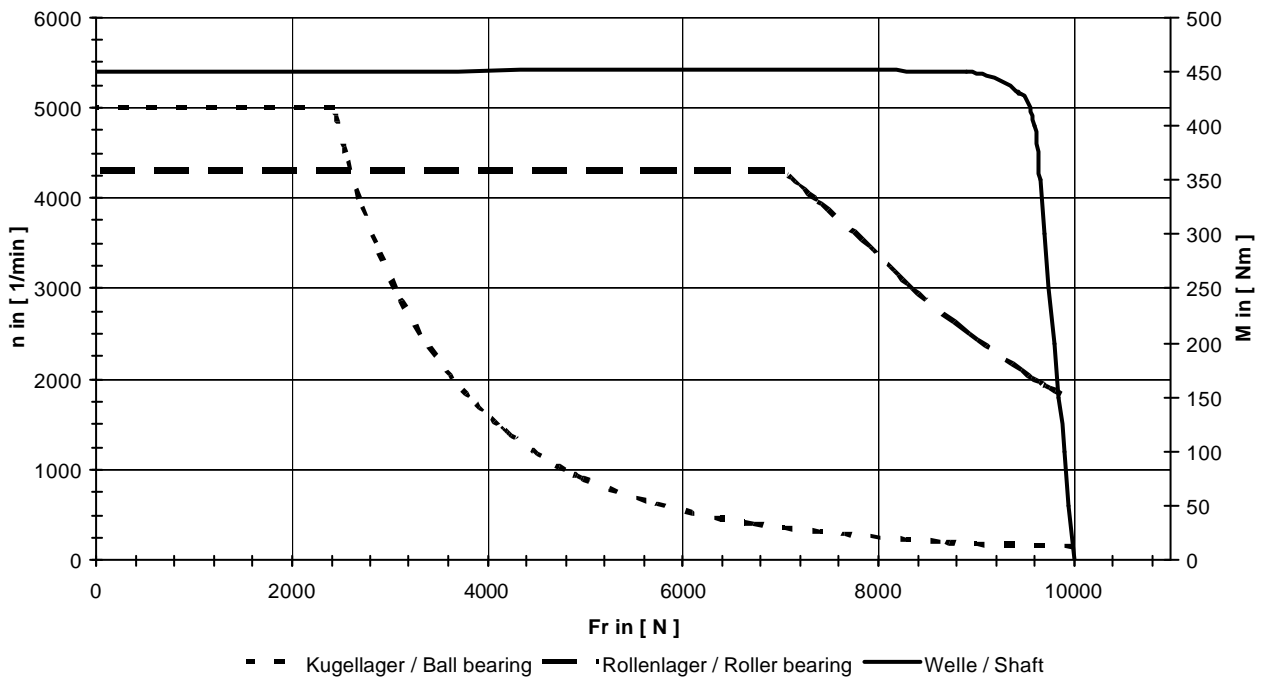

DA 160 / DS 160

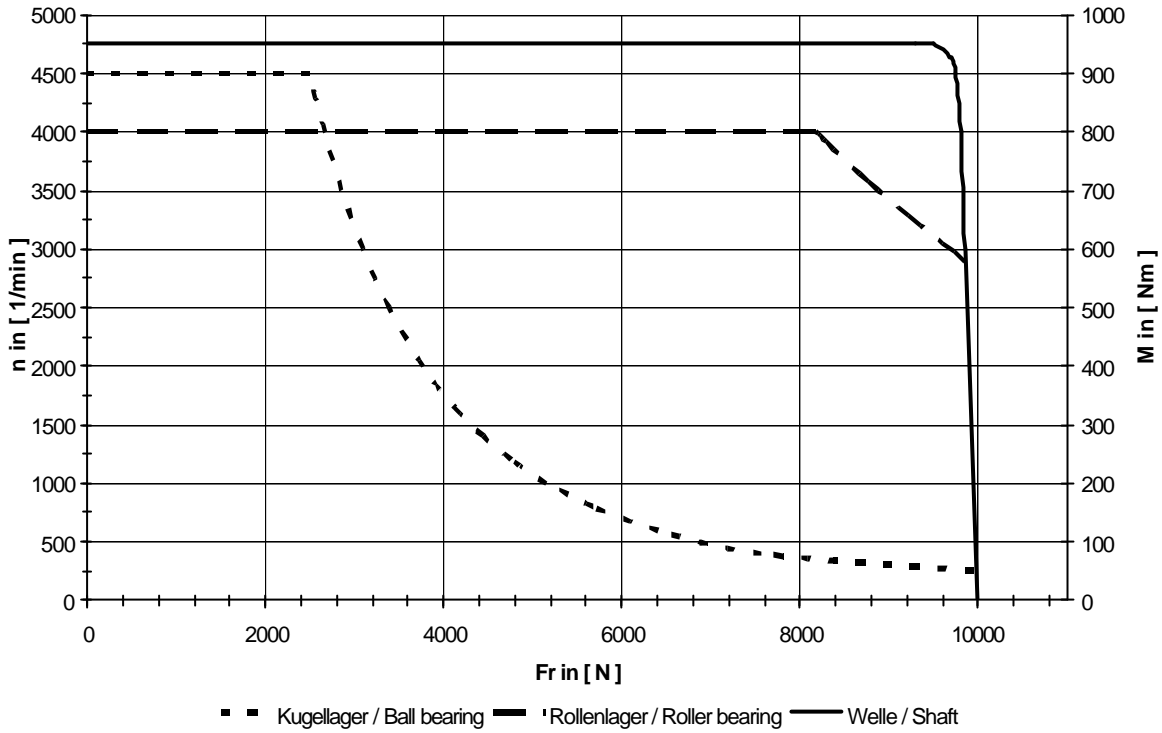

DA 180

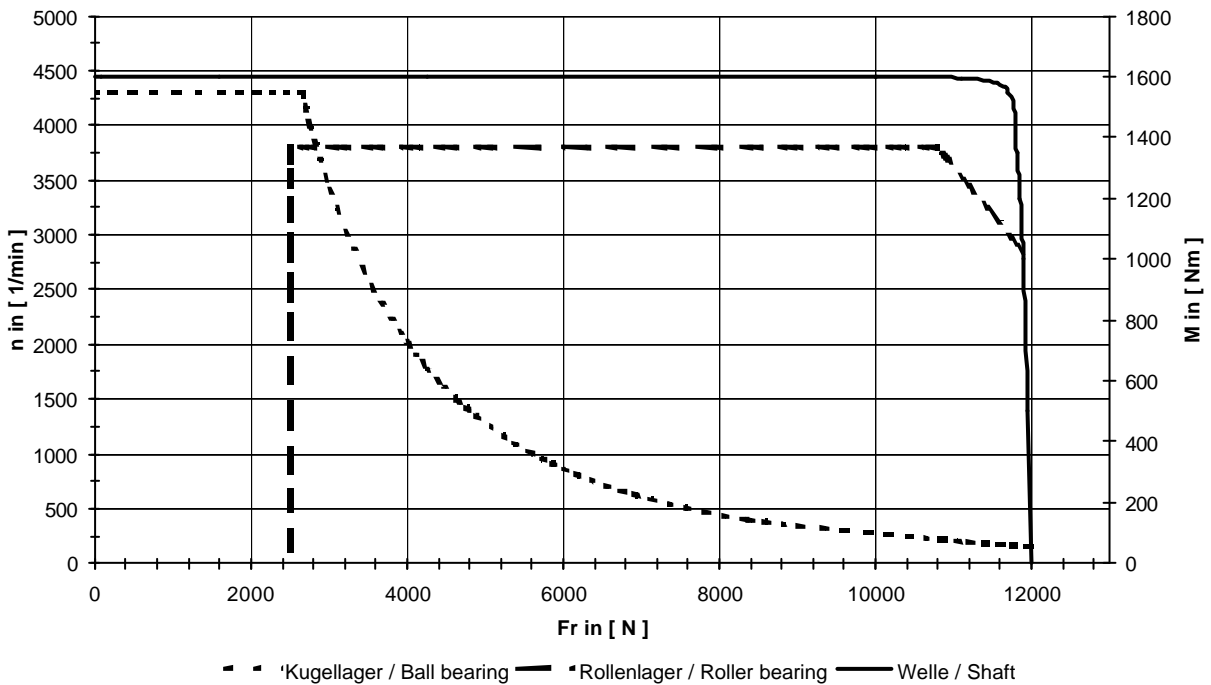

DA 225

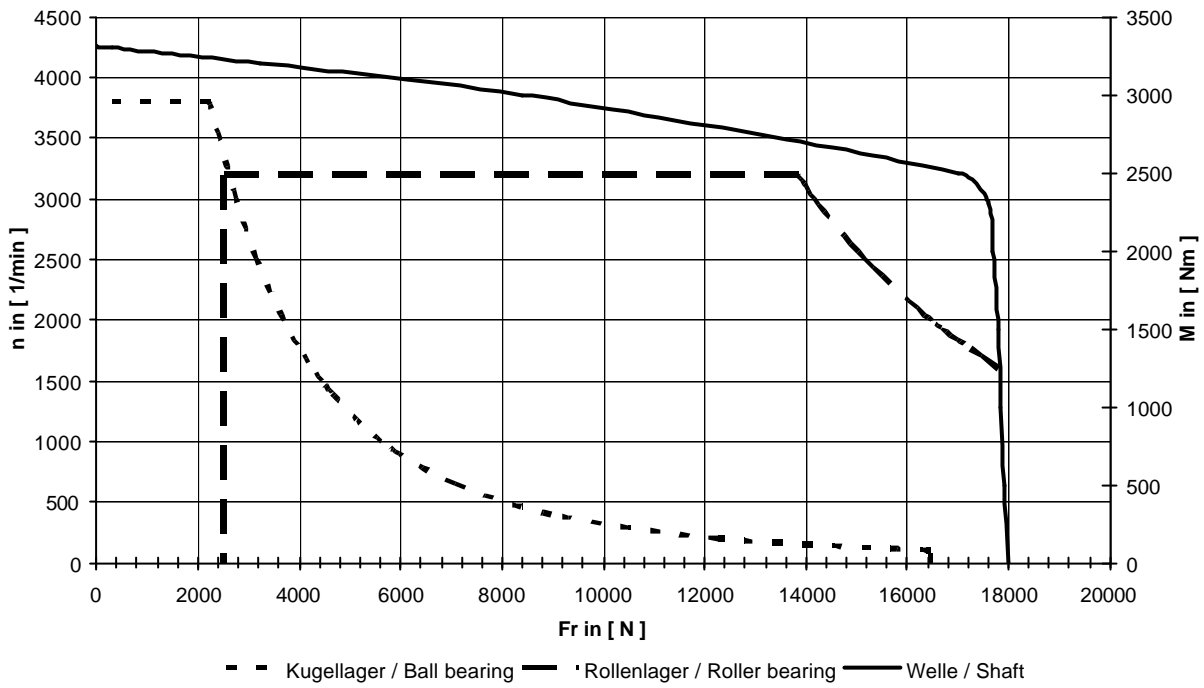

### Main connection – Terminal marking

Connection diagram

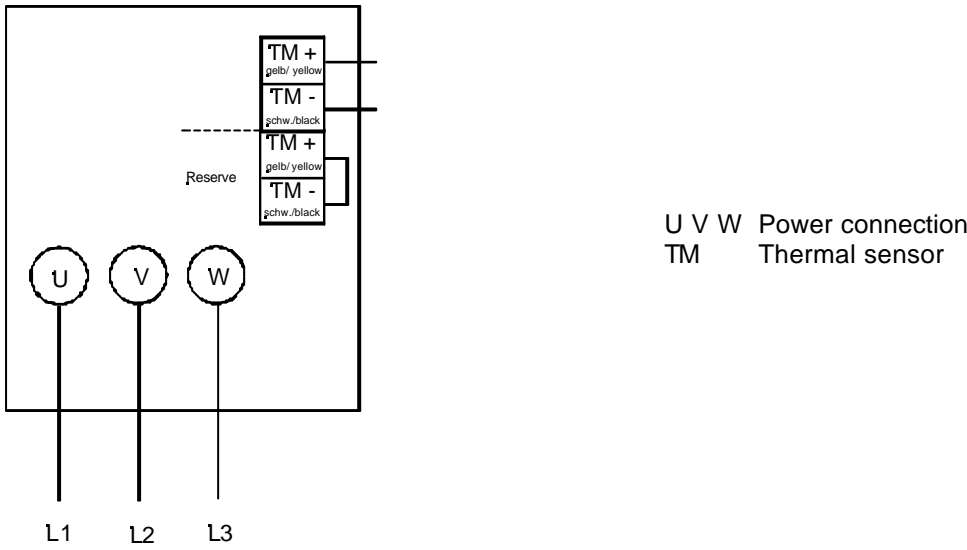

Frame size	100	132	160
Stud	8 M	10 M	12 M
Metric gland	1xM16 1xM40	3xM40 2xM25 2xM20	2xM63 2xM25

### Thermal sensor

As a standard, the motors are equipped with a thermal sensor in the stator winding; the data of which are evaluated in the motor controller. Additional PTCs or thermal sensors can be fitted on request.

KTY84 - 130

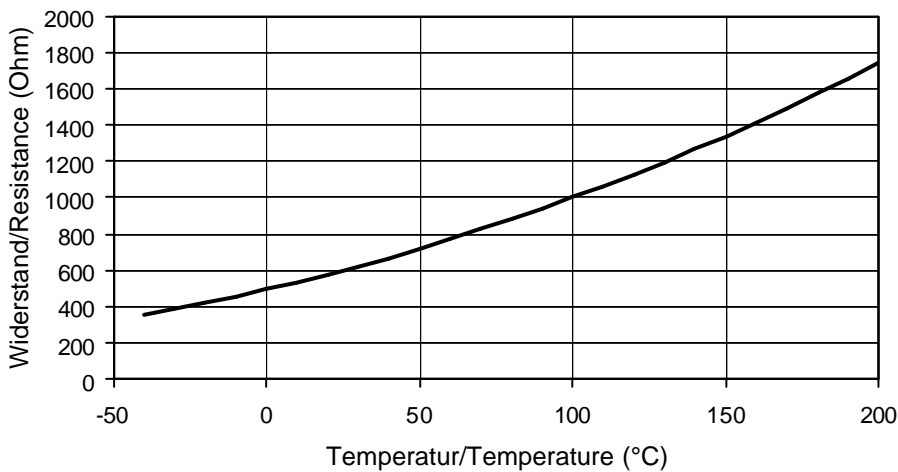

The motor temperature is continuously monitored using the thermal sensor type KTY 84-130. The above shown resistance results when the sensor is supplied with a measuring current of 2 mA.

## Noise intensity

The motors do not exceed the limit values specified in EN 60034.

## Vibration severity

Vibration severity	Speed [ min <sup>-1</sup> ]	Frame size	
		100-132 V <sub>eff</sub> [mm/s]	160-225
N (normal)	600 - 1800 > 1800	1,8 1,8	2,8 2,8
R* (reduced)	600 - 1800 > 1800	0,71 1,12	1,12 1,8
S* (special)	600 - 1800 > 1800	0,45 0,71	0,71 1,12

- The motors can be supplied in three vibration classes according to DIN ISO 2373.
- R and S are available with ball bearings only

## Requirements on the cooling circuit for liquid-cooled motors

The cooling circuit for water-cooled motors must meet the following requirements:

- Closed cooling circuit
- Water input temperature 10°C to 35°C maximal 5 K lower than ambient temperature
- Clear water without suspended matter or dirt
- Anti-corrosion agent added
- Water hardness 8 to 14 dH°
- pH range 6.5 to 7.5
- desalted and demineralized water: sodium chloride content (salt content) < 100 ppm (=0.01%)

The following amounts of coolants are necessary to cool the motors

DS frame size	100	132	160
Flow rate [l/min] (min.)	7 (4.5)	9 (6.5)	10 (7)
Pressure drop [bar]	0.29 ±10%	0.33 ±10%	0.15 ±10%
Temperature rise [K] (max.)	6 (10)	7 (10)	8 (11)

DA frame size	100	132	160	180	225
Flow rate [l/min] (min.)	7 (5)	9 (6.5)	11 (9)	12 (10)	13 (11)
Pressure drop [bar]	0.29 ±10%	0.33 ±10%	1.05 ±10%	1.35 ±10%	2.55 ±10%
Temperature rise [K] (max.)	6 (9)	7 (10)	8 (10)	10 (12)	11 (13)

Maximum pressure: 5 bar

## Brake assignment

For frame size	Brake type	Brake torque M4 for holding brake [Nm]	Input power [W]	max. perm. switching energy W <sub>perm.</sub> per switching operation [kJ]	Disengaging time [s]	Engaging time [s]	Inertia [kgm <sup>2</sup> ]	max. perm. speed [min <sup>-1</sup> ]	Weight [kg]
100	SB 100	100	106	18	0.180	0.250	0.0015	3500	9.5
132	SB 200	200	170	20	0.225	0.300	0.0040	3000	13
160	SB 360	360	190	30	0.350	0.300	0.0090	3000	29
180		On request							
225		On request							

For use as a **holding brake** the following must be observed:

The brake has a considerably increased brake torque

**3 emergency stops** (individual braking operations) per hour are possible if evenly distributed

Switching times values are valid for switching on the AC side, in a cold state, with basic air gap and holding brake

Disengaging time – Time until the brake has completely disengaged (brake without torque)

Engaging time – Time until the brake torque is reached

M4 ... static torque

All information are valid for the installation on a horizontal shaft

The supplier must be contacted before vertical installation.

Requirements other than those indicated on request.

### Brake time / Switching energy

It is necessary to check that the brake is suited for its application. For this, the switching energy must be determined.

#### Determination of the braking time [t<sub>B</sub>]

$$t_B = t_B = \frac{\sum J \cdot \Delta n}{9,55 \cdot (M_B \pm M_L)} + t_0 \quad \text{in s}$$

$\sum J$  Total moment of inertia in kgm<sup>2</sup> = J<sub>mot</sub> + J<sub>add</sub> (referred to motor shaft)

J<sub>mot</sub> Motor moment of inertia in kgm<sup>2</sup>

J<sub>zus</sub> Additional moment of inertia in kgm<sup>2</sup> (referred to motor shaft)

$\Delta n$  Motor speed in min<sup>-1</sup>

M<sub>B</sub> Brake torque in Nm

M<sub>L</sub> Load torque in Nm (positively calculated if it decelerates, negatively calculated if it accelerates)

t<sub>0</sub> Time in s from the switching instant to the full extent of the braking torque (response time)

l Number of cycles per hour

#### Determining the switching energy [W<sub>R</sub>]

$$W_R = \frac{\sum J \cdot \Delta n^2}{182.4} \cdot \frac{M_B}{(M_B \pm M_L)} \quad \text{in } \frac{\text{Joule}}{\text{switching operation}}$$

W<sub>Rperm</sub> ≤ Value from table

In most cases, t<sub>0</sub> is negligible. If this is not the case and the time t<sub>0</sub> must be reduced, you can achieve this by interrupting the magnet circuit on the DC side.

However, this measure must be known before dimensioning the brake motor.

### Brake supply

Normal voltage: 104 V DC (other voltages on request) . Anschlussspannung : 230 V 50 Hz AC

The voltage is supplied via the loosely attached brake supply device.

The brakes have a microswitch. Switching capacity of microswitches

Ohmic load up to 30 V DC - 5 A or 250 V AC - 5 A, inductive load up to 30 V DC -3 A or 250 V AC -2 A

The contact ratings apply to silver contacts

If you want to release the brake manually, please contact Baumüller.

**Encoder**

**Resolver**

Pole pair number	1
Ratio	0.5
Frequency	5 kHz
Nominal input voltage	4V
Active input power for no-load operation	112 mW
Current consumption for no-load operation	40mA
Max. output voltage for no-load operation	2 V eff
Voltage constant	
Rotor resistance	44 $\Omega \pm 10\%$
Stator resistance	28 $\Omega \pm 10\%$
Rotor impedance for no-load operation	70 + j 74 $\Omega \pm 15\%$
Rotor impedance at short-circuit	62 + j 66 $\Omega \pm 15\%$
Stator impedance for no-load operation with min. coupling	108 + j 206 $\Omega \pm 15\%$
Stator impedance at short-circuit and maximum coupling	97 + j 183 $\Omega \pm 15\%$
Phase shift	8°
Zero voltage	15 mV / °
Phase error referred to zero position	10'

**Resolver connection**

	Pin	Signal
	1	cos -
	2	
	3	
	4	
	5	sin -
	6	sin +
	7	
	8	cos +
	9	
	10	Ref +
	11	
	12	Ref -

View to contact side of female connector



**SINCOS SRS/SRM 50 (Stegmann)**

	SRS 50 / SRM 50
Number of sine, cosine periods per revolution	1024
Number of increments per revolution	32768
Number of absolute resolved revolutions	1   4096
Code type for the absolute value	Binary
Output frequency of sine, cosine signals (kHz)	0 ... 200
Error limits when evaluating 1024 signals, integral non-linearity (arc seconds)	+/- 45
Non-linearity within a sine, cosine period; differential non-linearity (arc seconds)	+/- 7
Working speed up to which the absolute position can be formed (1/min)	6000
Maximum operating speed (1/min)	12000
Output signals; 2 x 90° shifted sinusoidal signals ( $V_{pp}$ )	1
Output signal	serial RS 485, asynchronous, halfduplex
Operating voltage range (V)	7 ... 12
Operating current without load (mA)	80

**SRS/SRM 50 connection**

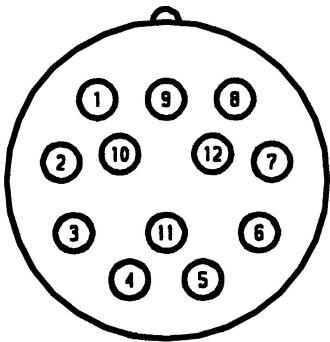
	Pin	Signal
	1	ref cos
	2	+ 485
	3	
	4	
	5	sin
	6	ref sin
	7	- 485
	8	cos
	9	Screening
	10	Gnd
	11	
	12	+ U

View to contact side of female connector

**ECN 1313 EQN 1325 (Heidenhain)**

		ECN 1313 / EQN 1325	
Number of sine, cosine periods per revolution	2048		
System accuracy in arc seconds	± 20		
Number of absolute resolved revolutions	1	4096 ( 12 bit)	
Code type for the absolute value	EnDat		
Sampling limit frequency or limit frequency (kHz)	0 ... 200		
Position values / revolution	8192 ( 13 bit )		
Working speed up to which the absolute position can be formed (1/min)	12.000		
Maximum operating speed (1/min)	12000		
Voltage supply (V)	5 V ± 5%		
Current consumption without load (mA)	≤ 150	≤ 250	

**ECN 1313 EQN 1325 connection**

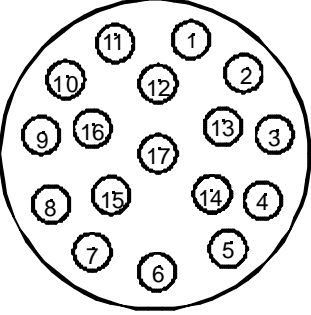
	Pin	Signal
	1	U <sub>p</sub>
	2	
	3	
	4	0V
	5	
	6	
	7	U <sub>p</sub>
	8	Clock
	9	Clock inv.
	10	0V
	11	
	12	B+
	13	B-
	14	Data
	15	A+
	16	A-
	17	Data inv.

We recommend not to use optical encoders for motors with a vibration resistance of more than 3g.

### Dimension drawing of encoder boxes and connectors

Female connector

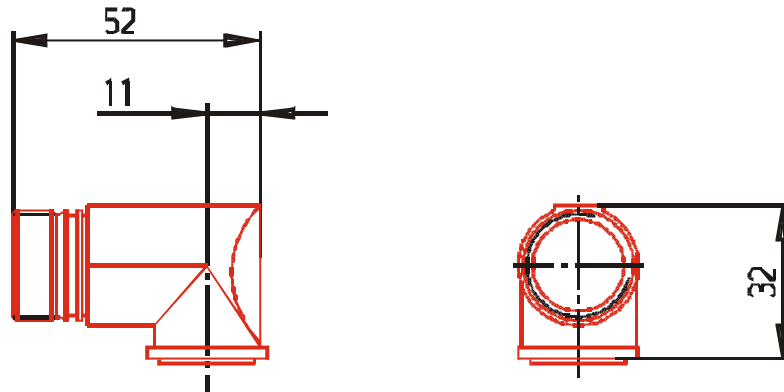

Male connector

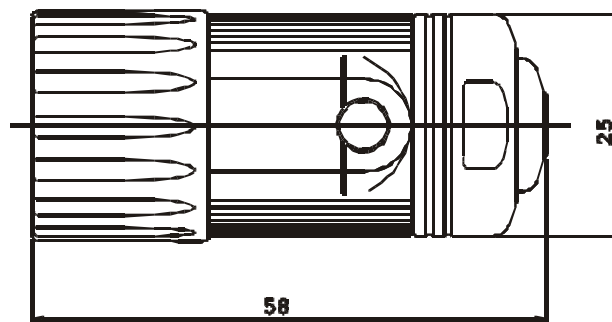

### Commissioning and maintenance instructions

Please contact us for our commissioning and maintenance instructions for motor commissioning.







## Drive Center National

### *Darmstadt*

#### **Baumüller Griesheim GmbH & Co. KG**

Waldstraße 1 • D-64347 Griesheim  
Tel +49- (0)6155 8430-00 • Fax +49- (0)6155 8430-20

### *Düsseldorf*

#### **Baumüller Nürnberg GmbH**

Jacob-Kaiser-Str. 7 • D-47877 Willich-Münchheide  
Tel +49- (0)2154-487-0 • Fax +49- (0)2154-487-59

### *Dresden*

#### **Baumüller Kamenz GmbH**

Nordstraße 57 • D-01917 Kamenz  
Tel +49- (0)3578 3406-0 • Fax +49- (0)3578 3406-50

### *Hannover*

#### **Baumüller Nürnberg GmbH**

Bohlenweg 10 • D-30853 Langenhagen  
Tel +49-(0)511 771968-0 • Fax +49- 0)511 771968-77

### *Nürnberg*

#### **Baumüller Nürnberg GmbH**

Ostendstr. 80-90 • D-90482 Nürnberg  
Tel +49- (0)911-5432-501 • Fax +49- (0)911-5432-510

### *Stuttgart*

#### **Baumüller Griesheim GmbH & Co. KG**

Hahnweidstr. 21 • D-73230 Kirchheim / Teck  
Tel +49- (0)7021-48557-10 • Fax +49-(0)7021-48557-77

## Drive Center International

### *Australia / Sydney*

#### **Baumüller Australia Pty. Ltd.**

Unit 4, 476 Gardeners Road  
Alexandria NSW 2015, Australia  
Tel +61 2 8338-0386 • Fax +61 2 8338-0389

### *Australia / Melbourne*

#### **Baumüller Australia Pty. Ltd.**

45 Jarrah Drive • Braeside Vic. 3195, Australia  
Tel +61 3 9580-9522 • Fax +61 3 9587-3886

### *Austria*

#### **Baumüller Austria Ges.mmbH**

Im Bäckerfeld 17 • A-4060 Leonding  
Tel +43 (0)732 674414-0 • Fax +43 (0)732 674414-32

### *China / Hong Kong*

#### **Baumüller Australia Pty. Ltd.**

13H, Block 4, Carado Garden,  
Tai Wai • N.T., Hong Kong  
Tel/ Fax +852 2695-9755 Handy +852 9194-1582

### *England*

#### **Baumüller (UK) Ltd.**

14 Redlands Centre • GB-Coulsdon, Surrey CR5 2HT  
Tel +44(0)208 76329-90 • Fax +44(0)208 76329-59

### *France*

#### **Baumüller France S.à.r.l.**

Zone de la Malnoue  
39, Avenue de l'Europe • F- 77184 Emerainville  
Tel +33 1 6461-6622 • Fax +33 1 6461-6006

### *India*

#### **Baumüller KAT India Pvt. Ltd.**

Dattaprasad Apartment • Flat No. 7, 3Rd Floor,  
B/7, 1206, APTE Road • IND- 411 004 Pune  
Tel +91 20 5513311 • Fax +91 20 5513388

### *Italy*

#### **Baumüller Italia s.r.l.**

Viale Italia, 12 • I-20094 Corsico (Mi),  
Tel +39 02 45100-181 • Fax +39 02 45100-426

### *Slovenia*

#### **Baumüller Dravinja d.o.o.**

Delavska cesta 10 • SI-3210 Slovenske- Konjice  
Tel +386 3-75723-00 • Fax +386 3-75723-32/33

### *Switzerland*

#### **Baumüller Suisse S.A.**

Rue des Usines 22 • CH-2000 Neuchâtel  
Tel +41 (0)32 7301-260 • Fax +41 (0)32 7301-351

### *The Netherlands*

#### **Baumüller Benelux B.V.**

Platinastraat 141 • NL-2718 SR Zoetermeer  
Tel +31(0)79-3614-290 • Fax +31(0)79-3614-339

### *Turkey*

#### **BAUMÜLLER MOTOR KONTROL SISTEM**

#### **SAN. VE TIC. LTD. STI**

Colak Ismail Sok., No:31/1 • TR-81070 Istanbul-Suadiye  
Tel +90 (0)216 372-2485 • Fax +90 (0)216 372-7570

### *USA*

#### **Baumüller Hartford Inc.**

117 West Dudley Town Road • USA-Bloomfield,  
CT 06002  
Tel +1 860 -243 0232 • Fax +1 860 -286 3080

### *USA*

#### **Baumüller Chicago Corp.**

405 Algonquin Rd. • USA-Mount Prospect, Ill 60056  
Tel +1 847 956-7392 • Fax +1 847 956-7925

## Representatives International

### *Brasil*

#### **NC SERVICE INDÚSTRIA E COMÉRCIO LTDA.**

Av. Juruá, 150, - Barueri - SP • BR- 06455 - 010  
Tel +55 (0)11 4195-0502 • Fax +55 (0)11 4195-2479

### *Czech Rep.*

#### **ATEM CNC- TECHNIK spol.s.r.o.**

V domove 4 • CZ- 130 00 Praha 3  
Tel u. Fax +420 222587698

### *Hungary*

#### **MELTRON KFT.**

Gyömroi ut. 128. • H-1103 Budapest  
Tel/ Fax +36 1 264 - 9482

### *Iran*

#### **PAK GOSTAR Co.**

502, 5th Floor, BORJE SEFID, PASDARAN Ave  
TEHRAN - IRAN  
Tel +98 21 2553868-70 • Fax + +98 21 2547703

### *Japan*

#### **NUSCO CO Ltd.**

6-17-8 Nagayama, Tama, Tokyo • J- 206-0025  
Tel +81 (0)423 73-1621 • Fax +81 (0)423 73-1821

### *Korea*

#### **BOMAC SYSTEMS**

712 Yucheon Factophia • 196 Anyang-7 dong, Mananku,  
Anyangsi. • Kyungkido 430-017, Korea  
Tel +82 31 467-2030 • Fax +82 31 467-2033

### *Poland*

#### **MECTEC POLSKA**

Ul. Mickiewicza 19 • PL-60833 Poznan  
Tel. / Fax +48 (0)61 - 8470553

### *Russia*

#### **Elektroprivod J.-s.**

st. Sadovaja- Spaskaja  
h. 1/2, b.2 • Moscow, 107078  
Tel +7 (0)95 2082-160 • Fax +7 (0)95 2082-623

### *Spain*

#### **Ofisistelec, S.L.**

Poligono Industrial Virgen de los Dolores  
E-46113 Moncada (Valencia)  
Tel +34 96 144-5055 • Fax +34 96 144-5311

### *Sweden*

#### **OCTAB Industrialelektronik AB**

Maskingatan 8B • SE-195 60 Märsta  
Tel +46 (8) 591 150-00 • Fax +46 (8) 591 150-01

### *USA*

#### **Industrial Drives Design, Inc.**

668 Flinn Avenue Unit 28 • USA- Moorpark  
CA 93021  
Tel +1 805 378-1170 • Fax +1 805 378-1171

### *Venezuela, Columbia, Ecuador*

#### **Nimbus International C.A.**

C.C. Parque Tuy, Local P-18  
YV-Ocumare del Tuy 1209  
Tel +58(0)39-251347 • Fax +58(0)39-257149

## Manufacturing locations

### *Motors*

#### **Baumüller Nürnberg GmbH**

Ostendstraße 80- 90 • D-90482 Nürnberg  
Tel +49- (0)911-5432-0 • Fax +49- (0)911-5432-130

#### **Baumüller Nürnberg GmbH**

Werk Kitzingen  
Flößhafenstraße 2 • D-97318 Kitzingen  
Tel +49- (0)9321-70080 • Fax +49- (0)9321-700888

#### **Baumüller Brno s.r.o.**

Skalice nad Svitavou 72  
CZ- 67901 Skalice nad Svitavou,  
Tel +420 516-499 111 • Fax +420 516-499 117

#### **Baumüller Kamenz GmbH**

Nordstraße 57 • D-01917 Kamenz  
Tel +49- (0)3578 3406-0 • Fax +49- (0)3578 3406-50

### *Small Motors*

#### **Baumüller Nürnberg GmbH**

Werk Bad Gandersheim  
Flugplatzweg 2 • D-37581 Bad Gandersheim  
Tel +49- (0)5382 9805-0 • Fax 49- (0)5382 9805-55

### *Electronics*

#### **Baumüller Nürnberg Electronic GmbH & Co.**

Ostendstraße 80- 90 • D-90482 Nürnberg  
Tel +49- (0)911-5432-293 • Fax +49- (0)911-5432-328

#### **Baumüller Dravinja d.o.o.**

Delavska cesta 10 • SI-3210 Slovenske- Konjice  
Tel +386 3-75723-00 • Fax +386 3-75723-32/33

## Systems

#### **Baumüller Anlagen-Systemtechnik GmbH & Co. KG**

Ostendstraße 84 • D-90482 Nürnberg  
Tel +49- (0)911-54408-0 • Fax +49- (0)911-54408-749

## Services

#### **Baumüller Reparaturwerk GmbH & Co KG**

Andernacher Straße 19 • D-90411 Nürnberg  
Tel +49- (0)911-9552-0 • Fax +49- (0)911-9552-999

### *München*

#### **Baumüller München GmbH**

Meglingerstraße 58 • D-81477 München  
Tel +49- (0)89 748898-10 • Fax +49- (0)89 748898-75

Headquater: Baumüller Nürnberg GmbH • Ostendstraße 80-90 • D-90482 Nürnberg  
Tel +49 (0)911 5432 -0 • Fax +49 (0)911 5432 -130 •  
<http://www.baumueller.de>

**be in motion**

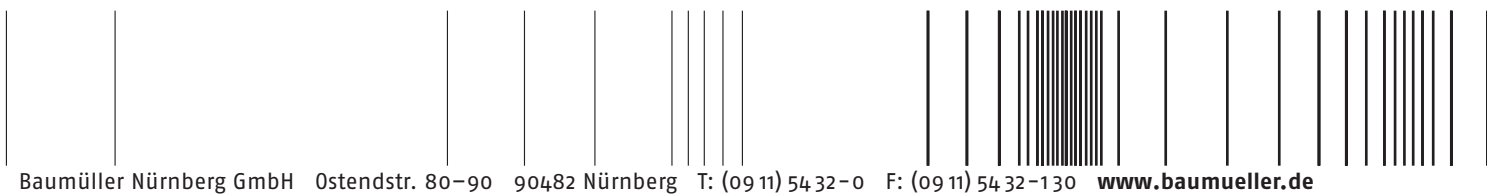

Baumüller Nürnberg GmbH Ostendstr. 80-90 90482 Nürnberg T: (09 11) 54 32-0 F: (09 11) 54 32-130 [www.baumueller.de](http://www.baumueller.de)

All data/information and particulars given in this brochure is non-binding customer information, subject to constant further development and continuously updated by our permanent alteration service. Please note that all particulars/figures/information is current data at the date of printing. These particulars are not legally binding for the purpose of measurement, calculation or cost accounting. Prior to using any of the information contained in this brochure as a basis for your own calculations and/or applications, please inform yourself about whether the information you have at your disposal is up to date. Therefore, no liability is assumed for the correctness of the information.

2.162.e.07/03.2020  
03/03